

driade
collection

1968

laboratorio estetico

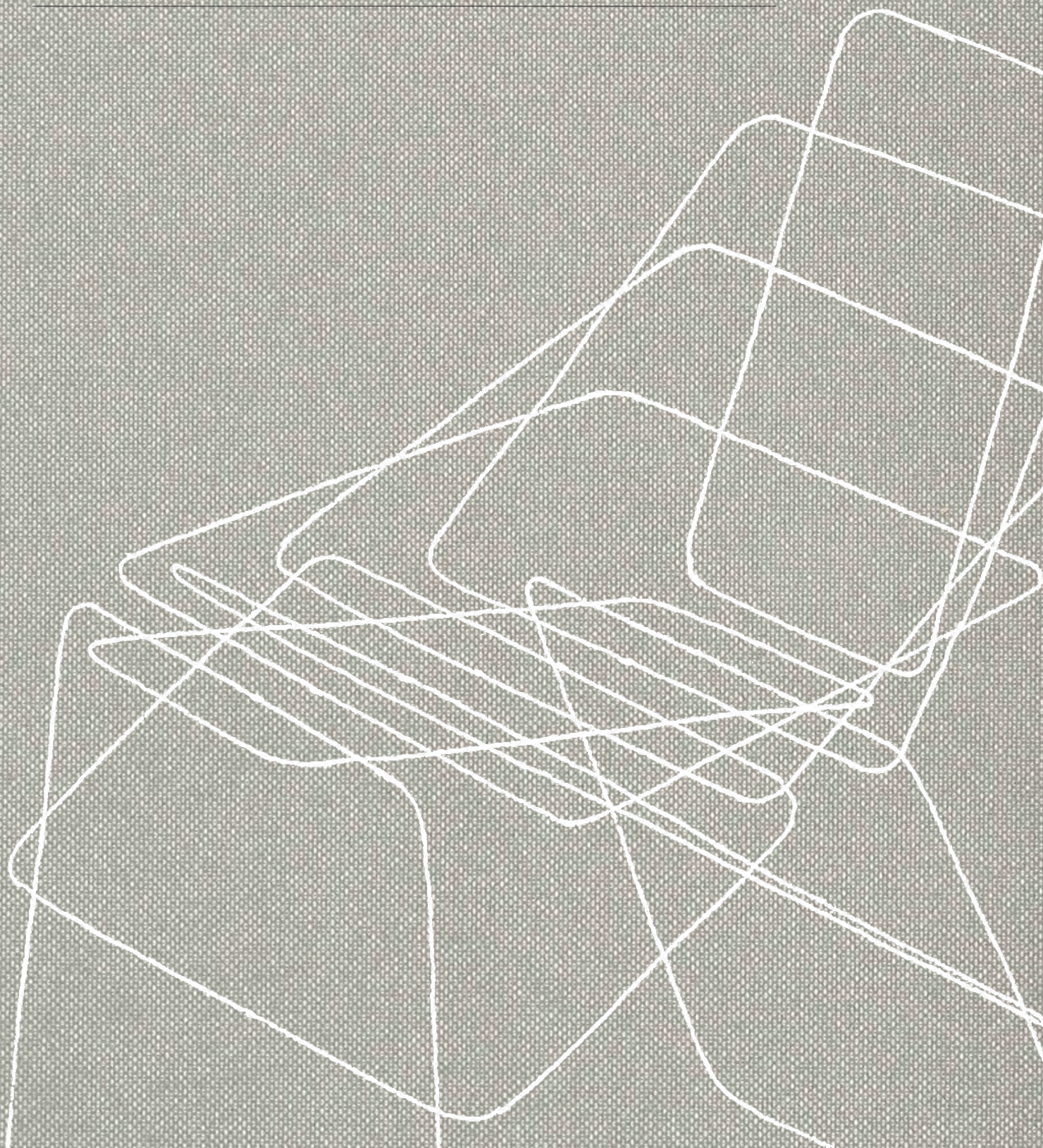

Fondata nel 1968, Driade ha raggiunto immediatamente un posizionamento estremamente riconoscibile nella fascia più esclusiva del mercato del design. La reputazione di Driade è inevitabilmente legata a grandi designer e personalità della cultura, autori di icone: Philippe Starck, Ron Arad, Fabio Novembre, Patricia Urquiola, Rodolfo Dordoni, Konstantin Grcic, Antonia Astori, Enzo Mari, Alessandro Mendini, Borek Sipek, per citarne alcuni. Una collezione che copre l'intera abitazione, da oggetti d'arte a strumenti per l'utilizzo quotidiano, oltre ad arredi per abitazioni uniche nel loro genere, giardini meravigliosi, uffici non convenzionali e spazi pubblici spettacolari. Da quella stagione in cui il design ha determinato una nuova corrente di pensiero, funzione ed immagine, Driade ne è uno dei grandi oratori, capace di coniare in anticipo una koiné compresa a tutte le latitudini proprio in quanto scritta da lingue e linguaggi diversi. Se fosse una città sarebbe New York o Londra o la Roma vissuta dal Caravaggio o più semplicemente la Milano della Famiglia Astori. Oggi abita in tante città, nelle dimore più esclusive o in quelle più stylish, provocando quel sinuoso equilibrio tra coerenza e cambiamento, tra rottura e cultura, seguendo quel mito della progettazione che va "dal cucchiaino alla città", in una collezione divenuta lifestyle. Lusso da intenditori. Con tale filosofia e joie de vivre, Driade rappresenta un mix eclettico pronto a sorprendere. Ecco perché Driade è LABORATORIO ESTETICO!

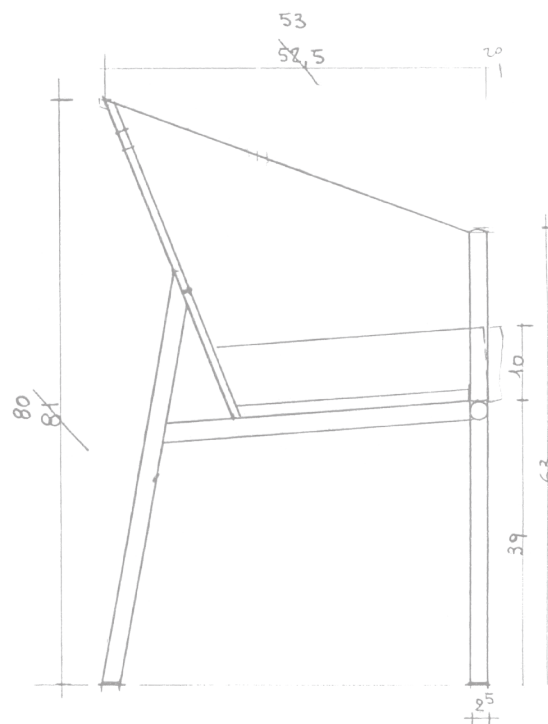

“Che senso ha il nostro lavoro se non possiamo continuamente sperimentare?”

ENRICO ASTORI
Fondatore di Driade

Founded in 1968, Driade quickly gained a well-recognised positioning in the High Luxury segment of the branded design furniture market. Driade’s reputation is linked to eminent designers and cultural personalities, authors of many icons: Philippe Starck, Ron Arad, Fabio Novembre, Patricia Urquiola, Rodolfo Dordoni, Konstantin Grcic, Antonia Astori, Enzo Mari, Alessandro Mendini, Borek Sipek among others. The collection covers the whole home and ranges from objects of art to daily use tools, furniture for one of a kind houses, marvelous gardens, smart office and flamboyant public spaces. From a season in which design determined a new trend in terms of mindset, function and image, Driade was one of the greatest representatives, being the first to invent a koiné that is understood at any latitude because written in different languages and codes.

If it were a city, it would be New York, London or even Rome at the time of Caravaggio, or more simply the Milano of the Astori Family. It now lives in many cities, in the most exclusive or stylish abodes, giving rise to a sinuous balance between coherence and change, break and culture, following the myth of design that goes “from the spoon to the town”, in a collection that has become lifestyle. True luxury. Following this philosophy and joie de vivre, Driade is an eclectic mix made to astonish. That’s why Driade is LABORATORIO ESTETICO!

“There is no point to work without experimentation!”

ENRICO ASTORI
Driade founder

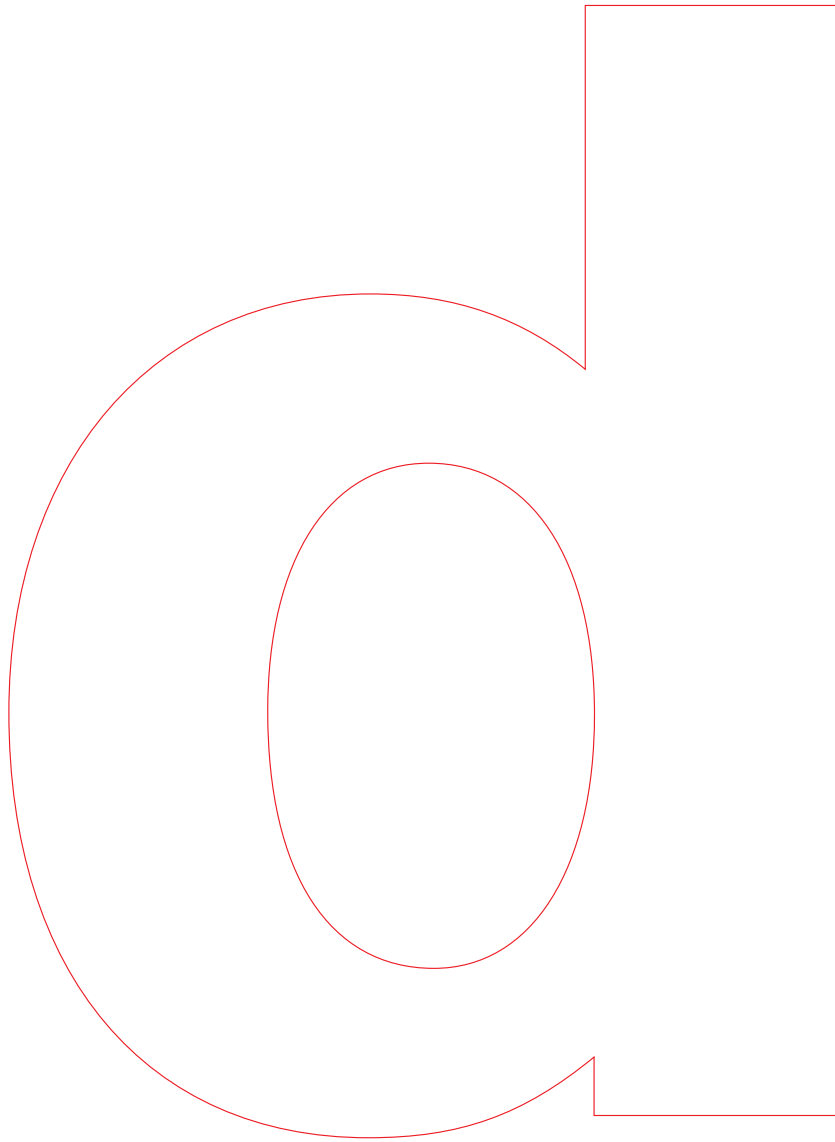

designers

Alberto Lievore
Antonia Astori
Antonio Rodriguez
Borek Sipek
Christophe Pillet
Dai Sugasawa
DriadeLab
Ed Annink
Elena Salmistraro
Enzo Mari
Eugeni Quitllet
Fabio Bortolani
Fabio Novembre
Faye Toogood
Francesco Bolis
Fredrikson Stallard
Gabriele e Oscar Buratti
Giuseppe Chigiotti
Gordon Guillaumier
Italo Rota
Jeannette Altherr
Kateryna Sokolova
Kazuyo Sejima
Konstantin Grcic
Ludovica + Roberto Palomba
Manel Molina
Marco Romanelli
Marta Laudani
Matteo Thun
Michel Rojkind
Miki Astori
Nanda Vigo
Naoto Fukasawa
Paolo Rizzatto
Park Associati
Patricia Urquiola
Philippe Nigro
Philippe Starck
Pietro Derossi
Rodolfo Dordoni
Ron Arad
Stefano Maffei
Studio Catoir
Tokujin Yoshioka
Toyo Ito
Vittorio Locatelli
Walter Becchelli
William Bertocco
Xavier Lust

Laboratorio estetico

2

**Sedie
Chairs**

8

**Tavoli e tavolini
Tables and coffee tables**

60

**Contenitori e librerie
Cabinets and bookcases**

134

**Complementi d'arredo
Furnishing accessories**

168

**Poltrone e divani
Armchairs and sofas**

188

Outdoor

284

Index

347

What's inside





SEDIE

chairs

Una collezione di sedute, tutte diverse l'una dall'altra. Ciascuna con la propria personalità.
Una collezione ricca ed eclettica quella di Driade; sedie di design, poltroncine, pouf e sgabelli
sapientemente realizzati in legno, cuoio, metallo, midollino o materiali plastici
a testimoniare l'amore per la ricerca e la sperimentazione
che da sempre contraddistingue l'operato del marchio.

A collection of chairs, all different; each with its own personality.
An eclectic collection, the one by Driade; chairs, easychairs, pouf and stools,
skillfully realized in wood, leather, metal, rattan and plastic materials
to testify driade passion for research and experimentation.



apple



costes

DESIGN _ PHILIPPE STARCK



Esistono oggetti che vengono universalmente riconosciuti come icone. La poltroncina Costes disegnata da Philippe Starck nel 1984 per l'omonimo caffè parigino deve il suo intramontabile successo all'assolutezza della forma: una scocca in legno avvolgente e tre gambe fortemente inclinate.

There are objects universally recognized as icons. Costes easy chair designed by Philippe Starck IN 1984 for the homonymous Parisian café, owes its timeless success to the absoluteness of forms: a wooden embracing structure with three highly tilted legs.









king costes

DESIGN _ PHILIPPE STARCK



Reinterpretazione della poltroncina Costes, King Costes ne modifica le dimensioni e la staticità, confermando l'assoluta riconoscibilità dell'immagine e la capacità di alcuni prodotti di durare nel tempo prescindendo dall'alternarsi delle mode.

As a reinterpretation of Costes chair, King Costes alters its size and increases its firmness while confirming the absolute recognition of this image and its durability against trends alternation.

pratfall

DESIGN _ PHILIPPE STARCK

La poltroncina Pratfall, disegnata da Philippe Starck nel 1984 e rieditata nel 2022, nasce assieme alla seduta Costes dalla quale prende le inconfondibili caratteristiche: una scocca in legno avvolgente e tre gambe fortemente inclinate.

The Pratfall armchair, designed by Philippe Starck in 1984 and reissued in 2022, was created together with the Costes chair from which it takes its unmistakable characteristics: a wooden embracing structure with three highly tilted legs.





la francesa

DESIGN _ LIEVORE ALTHERR MOLINA

La Francesa è una seduta elegante che si integra facilmente in qualsiasi tipo di ambiente. Le gambe, realizzate in frassino ebanizzato o in frassino naturale, sorreggono una scocca confortevole e avvolgente.

La Francesa is a refined seat that easily blends into any setting. The legs made of ebonised european ash or natural ash support the high comfort cozy body.





ENZO MARI CURATED
BY HANS ULRICH OBRIST





lou eat

DESIGN _ PHILIPPE STARCK WITH D. SUGASAWA



Poltroncina rivestita in pelle.
È pensata come seduta per la sala da pranzo ma
è perfetta anche come singola protagonista degli
spazi.

Small armchair upholstered in leather.
Conceived as a dining room seat, it is also ideal as
the sole protagonist of spaces.









“Lou Eat is not a chair,
it is an animal-like sculpture
that could eat you.”

PHILIPPE STARCK





miss lacy

DESIGN _ PHILIPPE STARCK

Caratterizzata dalla lucentezza dell'acciaio inox sapientemente traforato e finito a specchio, Miss Lacy acquista un'unicità che usualmente caratterizza piuttosto i gioielli che gli oggetti funzionali. È uno dei prodotti più artigianali dell'intera collezione Driade.

Obtained from the ancient lost wax casting technique, Miss Lacy represents and makes accessible a baroque lace by transforming it into an embracing shell. Characterized by the expertly pierced shiny mirrored stainless steel. It is unique that compares more to a jewel than to a functional object.





soirée

DESIGN _ OSCAR E GABRIELE BURATTI

Tipologia classica, il tema della sedia morbida e tessile, monomaterica e imbottita, è qui interpretato con particolare eleganza e cura nel disegno.

In tessuto o pelle, sempre da gran sera, rivela la sua contemporaneità nelle particolari proporzioni e nella curva del suo schienale; pensata sia per gli spazi privati del dining domestico che per quelli più pubblici della ristorazione e dell'hotellerie. Affida al dettaglio sofisticato della cucitura a contrasto il suo carattere forte e la sua presenza iconica.

The theme of the classic, soft, fabric-covered, padded chair made of a single material is interpreted here in an exceptionally elegant, accurately finished design. Whether dressed in fabric or leather, always ready for a great Soirée, the particular proportions and curve of its backrest reveal its contemporary attitude. This chair is designed both for private dining at home and for public places such as restaurants and hotels. Its strong personality and iconic appeal are conveyed by sophisticated, contrasting stitching.











“Chinese design has been
a great inspiration...
When I started the concept
I wanted to create
a design that really pays homage
to the culture”.

KONSTANTIN GRČIĆ



mingx

DESIGN _ KONSTANTIN GRCIC

Serie di seduta, poltrona, poltroncina e sgabelli caratterizzati dal profilo in tubolare. Seduta in cuoio per l'indoor e con cuscino per l'outdoor. Proposta nei colori bronzo, nero e arancio.

Set of chairs, armchairs, easychairs, and stools characterized by a tubular profile. Leather seat for indoor and cushion seat for outdoor. Colors: orange, bronze and black.











meridiana

DESIGN _ CHRISTOPHE PILLET

Diamante che si fa seduta,
Meridiana è realizzata nelle versioni
sedia, poltroncina e sgabello
con scocca in policarbonato
oppure in pelle.

Diamond that becomes seating,
Meridiana is available
in the version chair, easychair
and stool with shell in polycarbonate
or in leather.



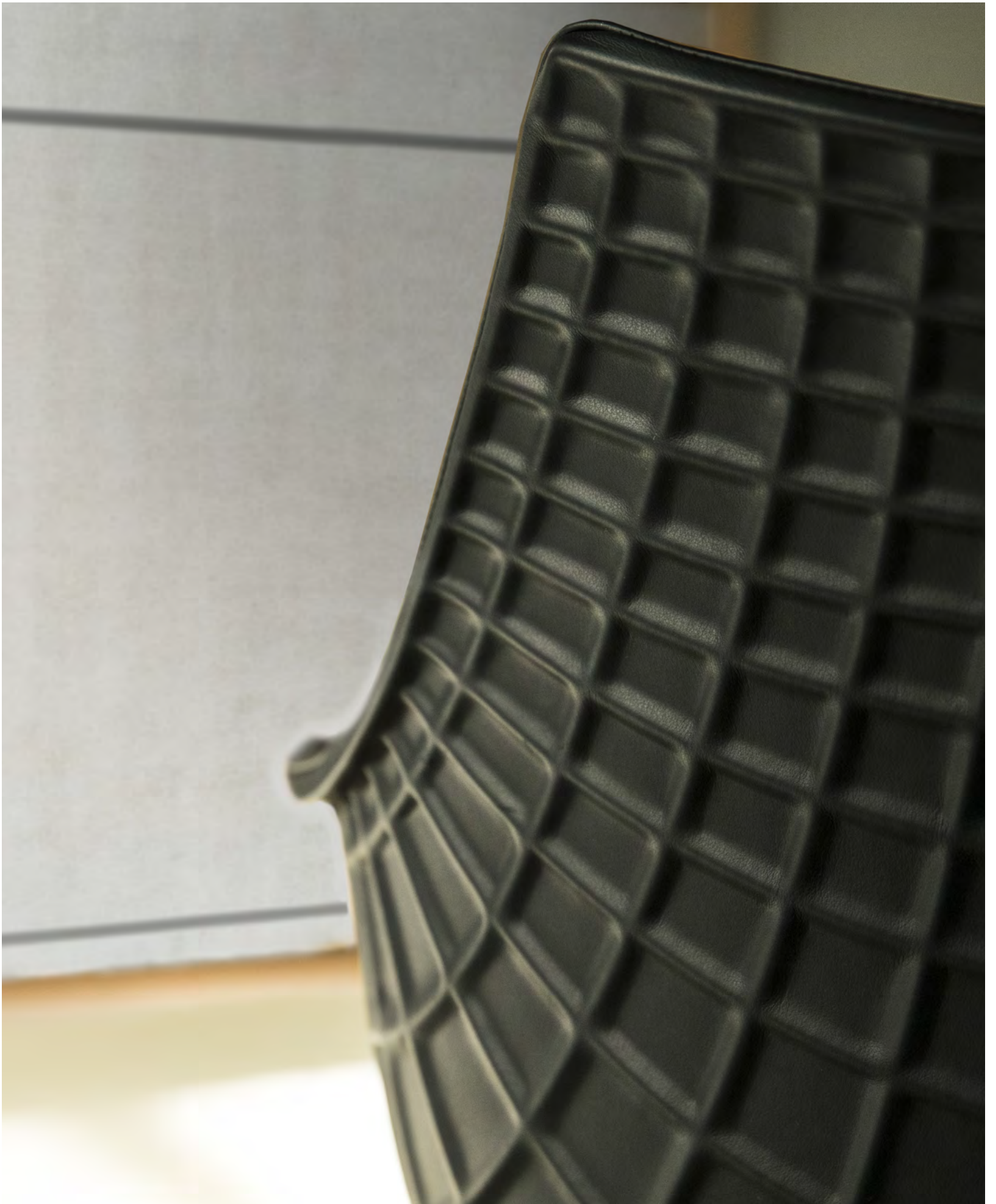

lagò

DESIGN _ PHILIPPE STARCK

Caratterizzata dalla forma avvolgente della scocca e delle gambe a “spillo”, Lagò viene esaltata dal colore assoluto e brillante che uniforma l'intera superficie. Disponibile anche in cuoio.



Characterized by the embracing shell and “stiletto” legs, Lagò is enhanced by intense and bright colors that smooth the entire surface. Also available in leather.







liba

DESIGN _ BOREK SIPEK

Sipek, artista artigiano capace di piegare la materia ai suoi desideri, trova nel rattan e nel midollino una straordinaria potenzialità. Ne discende una vitalità scultorea sospesa tra cubismo e barocco.

Sipek, artist and craftsman able to bend materials to his desires, finds a great potential in rattan and cane. The result is a sculptural vitality suspended between cubism and baroque.







neoz

DESIGN _ PHILIPPE STARCK

Neoz sposa la poetica del legno massello e rivisita gli archetipi formali della tradizione. Ne deriva una collezione “senza tempo”, caratterizzata da sezioni vigorose e dalla forza dell'immagine.

Neoz embraces the poeme of solid wood and reviews the traditional archetypes. The result is a “timeless” collection characterized by straight lines as well as by a strong image.



sof sof

DESIGN _ ENZO MARI

Realizzata da Driade nel 1972,
Sof Sof con le sue linee armoniose
riassume l'essenzialità e l'eleganza
del design di Enzo Mari.

Made by Driade in 1972,
Sof Sof reflects the essential elegance
of the design by Enzo Mari.

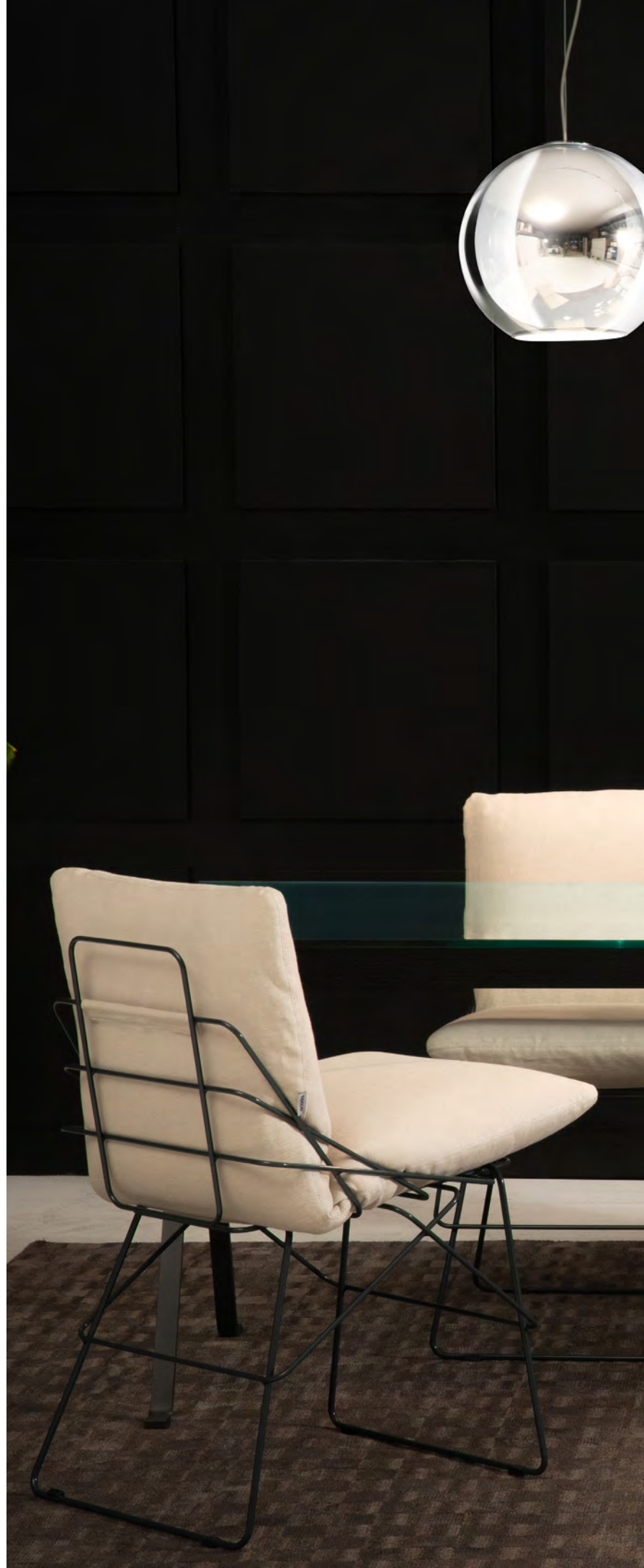



millepiedi

DESIGN _ STUDIO CATOIR

Millepiedi è ispirato dall'archetipo a tre gambe dello sgabello per mungitura, un oggetto semplice ancorchè curioso e valevole. La ripetizione enfatizza, in maniera giocosa, la bellezza del materiale naturale e del lavoro artigianale richiesto per creare ed assemblare i vari elementi. La moltiplicazione delle gambe evoca spontaneamente l'immagine proprio del "millepiedi." Il risultato finale è una panca versatile, intreccio di bellezza, eleganza e di sorpresa.

Millepiedi was inspired by the archetypal 3 legged milking stool, a simple minimalistic object yet intriguing and useful. The repetition emphasises, in a playful way, the beauty of the natural material and the skilful craftsman work required to assemble the various elements. The multiplication of the legs brings up spontaneously the image of the caterpillar "Millepiedi" (millipede in Italian). The final result is a versatile bench which brings together beauty, elegance and surprise.







“In a room for the well-being
many elements called “furniture”
are necessary that actually
once set remain “fixed”.
I always reject the tendency
to overload the space;
therefore I have always worked
to the limit of need”.

NANDA VIGO

blocco

DESIGN _ NANDA VIGO



La seduta Blocco nata con questo intento nel 1970 viene ora riproposta con la stessa funzione ma con un maggiore spirito di allegria nella scelta dei rivestimenti.

The seat Blocco born with this aim in 1970 is now re-edit with the same function but with a greater spirit of joy in the choice of covers.





TAVOLI E TAVOLINI

tables, coffee tables

Tavoli, ma anche tavolini da salotto, tavoli bassi, scrittoi.

Basta un piano, ma rispettoso della regola che lo vuole parallelo al suolo,
mentre le gambe possono sbizzarrirsi a volontà.

Tavoli rettangolari, tavoli rotondi e ovali, quadrati ma anche tavoli dalle forme inedite,
inaspettate e gioiose; icone della storia del design e nuovi protagonisti.

Tables, but also coffee tables, side tables and desks. It's enough that the top respects
the rule that wants it parallel to the ground, while the legs can indulge themselves at will.

Rectangular and round tables, squared and ovals, but also table with unexpected
and joyful shapes: icons of the history of design and new characters.







sangaku

DESIGN _ ELENA SALMISTRARO

Sangaku è un divertente gioco di intersezioni, rotazioni e variazioni dimensionali. Nella cultura giapponese infatti i Sangaku sono dei problemi geometrici incisi su tavolette di legno, che nella maggior parte dei casi illustrano problemi riguardanti cerchi ed ellissi inscritti l'uno nell'altro. Da qui l'idea di inscrivere all'interno di una circonferenza immaginaria di raggio 50 cm quattro diverse circonferenze, due da 40 cm e due da 20 cm di raggio, creando un nuovo elemento regolato da rapporti geometrici invisibili ma comunque percettibili. I punti di intersezione tra i vari elementi diventano le gambe a sostegno dei quattro differenti piani, che riescono sapientemente a colmare e differenziare lo spazio creando un mix perfetto di pieni e vuoti.

Sangaku is a fun game of intersections, rotations and dimensional changes.

In Japanese culture, Sangaku are geometric problems engraved on wooden tablets, which in most cases illustrate problems involving circles and ellipses inscribed one inside the other. This gave rise to the idea of inscribing four different circles, two with a radius of 40 cm and two with a radius of 20 cm, within an imaginary circle of 50 cm, creating a new element governed by invisible but nevertheless perceptible geometric relationships. The points of intersection among the various elements become the legs supporting the four different tops, which skillfully fill and differentiate the space, creating a perfect mix of solids and voids.









tottori

DESIGN _ KATERYNA SOKOLOVA

Tottori è una collezione di sedute e tavolini dalle forme senza tempo, dalla silhouette seducente e dal carattere audace. Ispirata al film d'animazione giapponese "Il mio vicino Totoro", scritto e diretto da Hayao Miyazaki, la collezione di arredi Tottori conferisce un'atmosfera intima e calda all'ambiente domestico grazie all'aspetto accogliente e morbido dei suoi componenti.

Tottori is a seating and coffee tables collection with timeless shapes, cute silhouette and bold character. Called after the Japanese animation film "My Neighbor Totoro", written and directed by Hayao Miyazaki, the Tottori furniture collection has a friendly and soft silhouette that brings a cozy mood in the house.



frate

DESIGN _ ENZO MARI

Con la consueta lucidità Enzo Mari decide di procedere, in questa collezione di tavoli, con piani in cristallo trasparente. Solo così sarà possibile valorizzare la scabra essenzialità dei supporti in profilati metallici. Disegnati nel 1973, da allora ininterrottamente in produzione, questi pezzi sono certamente annoverabili tra i più felici del maestro milanese.

Very lucidly, Enzo Mari decided to realize this tables collection with transparent crystal tops in order to valorise the harsh simplicity of steel sections bases. Designed in 1973, uninterruptedly produced since then, these pieces can be certainly numbered among the most successful of the Milan master.







fratello

DESIGN _ ENZO MARI





“There is more to a design object
than its appearance,
it is everything it represents”.

ENZO MARI







cugino

DESIGN _ ENZO MARI





cuginetto
DESIGN _ ENZO MARI









françois

DESIGN _ LIEVORE ALTHERR

Le gambe asimmetriche incorniciano il piano, che sembra sospeso nel vuoto, valorizzandolo. Gli angoli arrotondati, le forme morbide, l'estrema piacevolezza nel tatto rendono François un oggetto da amare nel vivere quotidiano.

The asymmetrical legs enhance the tabletop, making it look as if it is floating in mid-air. Its rounded corners, soft forms and extremely pleasant feel make it an object to fall in love with every day of the year.

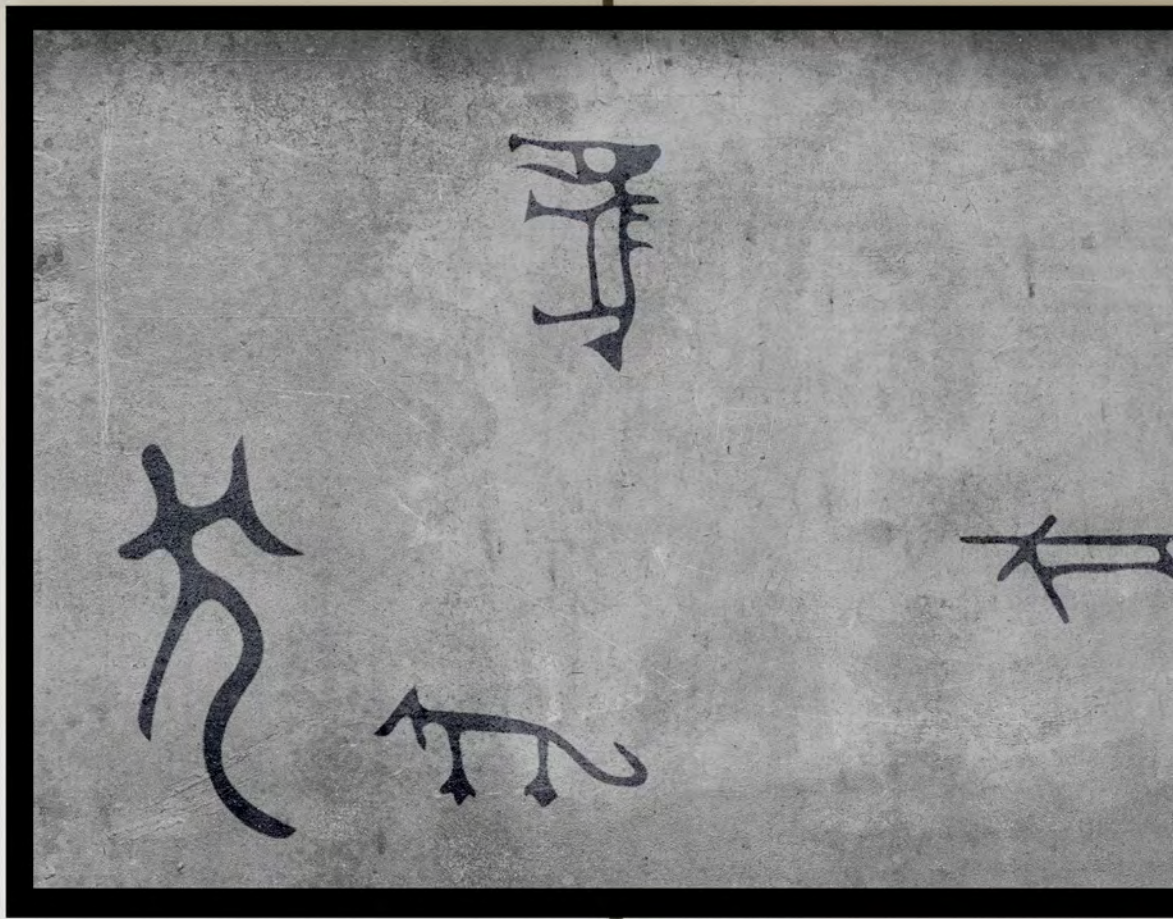







fourdrops

DESIGN _ OSCAR E GABRIELE BURATTI



Il rapporto tra elemento verticale portante, la gamba con sezione a goccia che dà il nome al progetto, e l'elemento orizzontale portato - il piano dalla sezione rastremata e arrotondato sugli angoli - costituisce un sistema di tavoli lussuosi nei materiali e puri nelle forme. Il sistema gamba/piano prevede diverse forme di tavolo, rettangolare e tondo. Da esaltare in spazi dalle dimensioni importanti, non solo grazie alle dimensioni ma anche grazie alla palette materica dove i legni naturali e laccati, i marmi venati e il vetro retroverniciato in vari colori, ne consentono diverse interpretazioni. Un progetto di architettura alla scala del design, dove essenza della forma e ricchezza del dettaglio costituiscono gli estremi di un processo creativo dei fratelli del design milanese, Oscar e Gabriele Buratti.

The relationship between the vertical support - the drop-section leg from which the project takes its name - and the horizontal top with tapered edges and round corners - forms an occasional table system featuring luxurious materials and pure lines. This leg/top system produces various rectangular or round table shapes which are best enhanced in large spaces. This is not merely due to their size but also thanks to the many materials available, including natural and lacquered wood, veined marble and glass lacquered on the reverse side in many colours, which inspire various interpretations. Minimalist shapes and rich details are the extremes of a creative process by Oscar and Gabriele Buratti, an architectural project scaled down to suit design. white carrara or nero marquina marble tops.

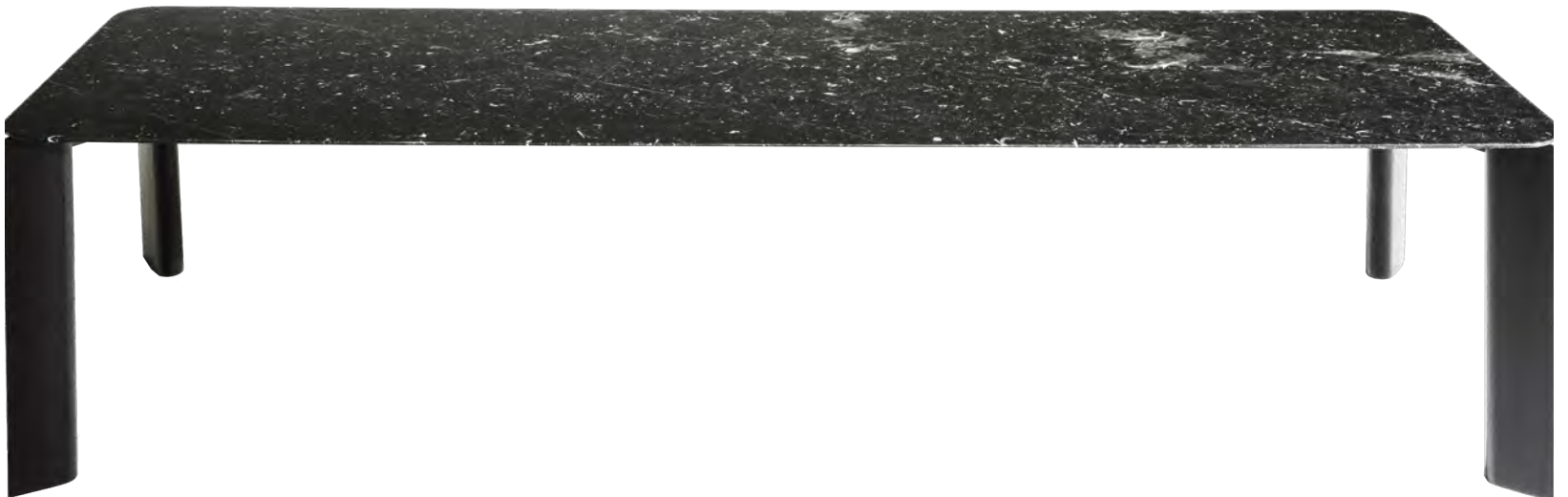













easel

DESIGN _ LUDOVICA + ROBERTO PALOMBA

Easel è un tavolo che gioca sulle proporzioni e la dinamicità. Disponibile in tre diverse lunghezze (220, 240 e 270cm), con struttura in massello di noce canaletto o in massello di frassino ebanizzato, ben si presta ad essere inserito in ogni ambiente, dal classico al contemporaneo.

Elegante elemento d'arredo, ha un aspetto aereo e trasparente.

Easel is a table that plays on proportions and dynamism. Available in three different lengths (220, 240 and 270 cm), with a structure in canaletto walnut or solid ebonized ash wood, this table is perfect for any room, from classic to contemporary styles.

This elegant piece of furniture has a transparent, airy look.









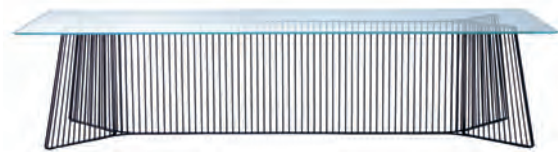

anapo

DESIGN _ GORDON GUILLAUMIER

Il piano del tavolo Anapo, è retto da una base scultorea in acciaio verniciato nero. Una sequenza di tubi metallici che dona tensione allo spazio, con un raffinato effetto di semitrasparenza. Ispirazioni anni sessanta, per una certa idea di casa borghese tesa tra rigore e morbidezza, tra lusso e funzionalità.

The Anapo table top is supported by a sculptural base in black painted steel, a sequence of metal tubes that gives tension to the space, with a refined semi-transparent effect. Its inspiration lies in the sixties and in a specific idea of conventional home torn between rigor and softness, between luxury and functionality.





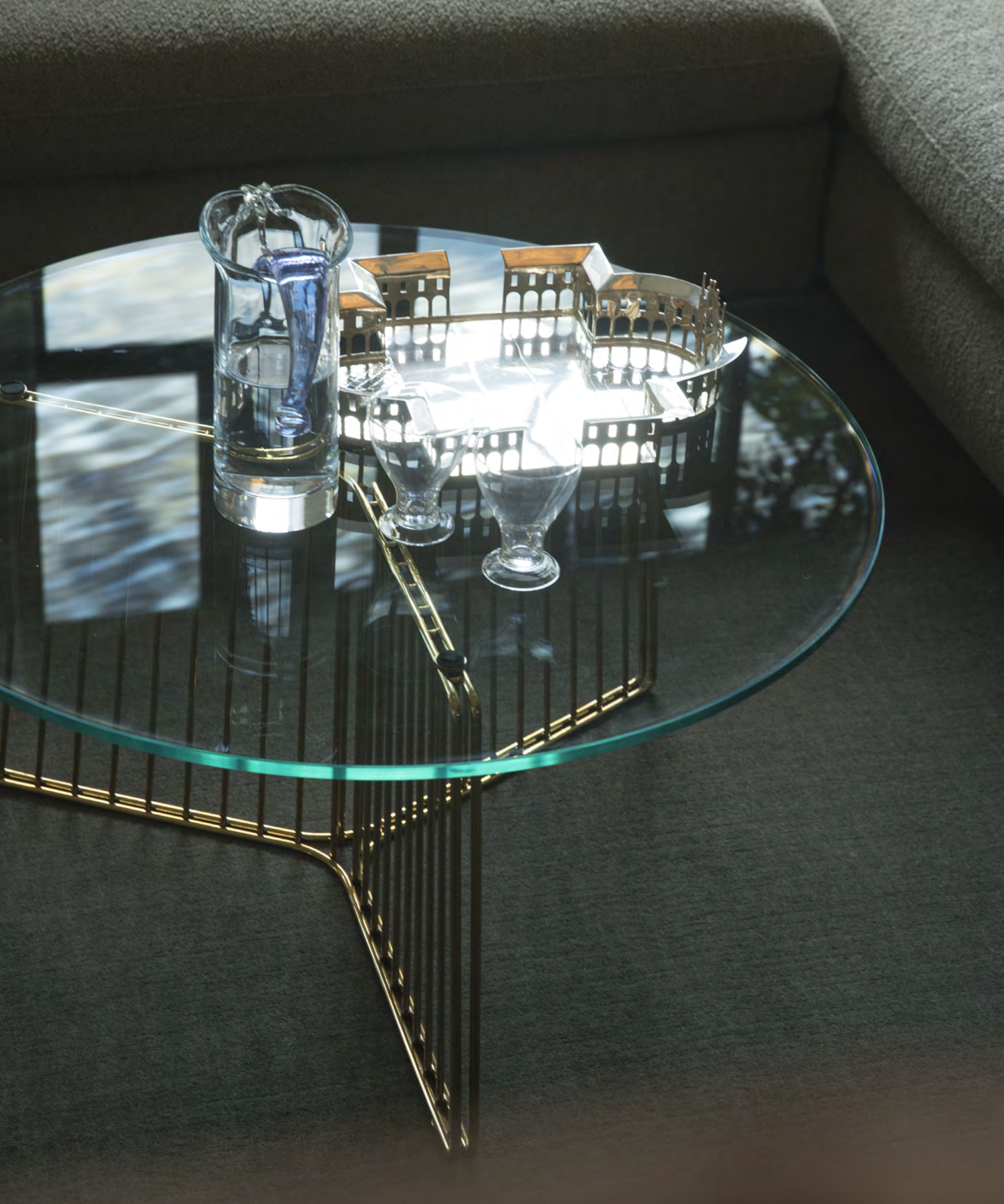



didymos

DESIGN _ ANTONIA ASTORI

Il tavolo ovale e il tavolo rotondo sono tavoli perfetti: nessuno spigolo, nessun capotavola, nessun commensale “dispari” e soprattutto una forma straordinaria nello spazio.

In a table, oval and rounded mean perfect: no edge, no head of the table, no “odd” diner and, above all, a form expanded in space.













mingx

DESIGN _ KONSTANTIN GRČIČ

I tavoli della collezione Mingx si distinguono per la caratteristica struttura dal profilo tubolare. I piani sono disponibili in noce canaletto, in metallo o in quarzite.

The tables of the Mingx collection differ for the characteristic structure with a tubular profile. The tops are available in Canaletto walnut, in metal or quartzite.





gazelle

DESIGN _ PARK ASSOCIATI

Un tavolo che gioca sul disequilibrio apparente, sostenendo un piano fortemente materico, su una sequenza di tre strutture posizionate in maniera del tutto imprevedibile.

A table that plays on an apparent imbalance, supporting a strongly materic top, by a sequence of three structures placed in a totally unpredictable way.









meridiana

DESIGN _ CHRISTOPHE PILLET

Dalla sedia globetrotter per eccellenza, rivisitata con gambe in legno massello, nasce il tavolo Meridiana. Archetipo del tavolino da caffè o domestico, si presenta con un prezioso equilibrio tra il piano (rotondo o quadrato) di particelle di legno e la struttura con gambe in legno massello. Rasatura a mano con spatola di un composto a base di argilla colorata in massa. Le sfumature dell'applicazione manuale caratterizzano l'estetica del prodotto. Nei colori: rosso vulcano, pece e champagne.

The Meridiana table stems from the ultimate globetrotter chair, revised with solid wooden legs. An archetype of the coffee shop or domestic table, it displays a precious balance between the round or square wood particleboard top and the solid wood frame and legs. A mass-coloured clay mixture is smoothed over the top by hand with a scraper. The table's aesthetic is distinguished by the shaded, handmade finish of its top. Available in the following colours: volcano red, lava black and champagne.



koishi

DESIGN _ NAOTO FUKASAWA

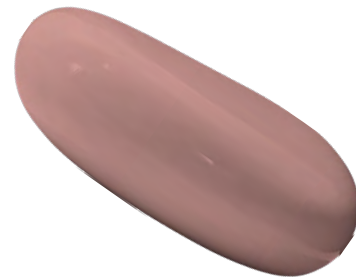
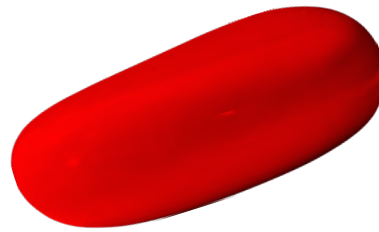

Dovessimo cercare un simbolo che racconti l'arte zen dei giardini giapponesi, probabilmente sceglieremmo un sasso (in giapponese "ishi"). Naoto Fukasawa partendo da un semplice ciottolo sviluppa un grande pouf.

If we should look for a symbol representing the Japanese gardens art, we would probably choose a stone (in Japanese "ishi"). Naoto Fukasawa develops a big pouf precisely by a small stone.









sereno

DESIGN _ FREDRIKSON STALLARD

Tavolo basso supportato da sculture con finitura metallizzata realizzata mediante tecnologia Sputtering nel colore titanio e oro. Piano in particelle di legno spessore rivestito con lamiera a forte spessore di acciaio inox lucidato a specchio oppure in vetro extrachiaro.

Sculpture legs in cast aluminum with metallic finish made by Sputtering technology in titanium color or gold color. Top in wood particles with a thick plate of mirror-polished stainless steel or extra clear glass.







carmina

DESIGN _ LUDOVICA + ROBERTO PALOMBA

Collezione di piccoli coffee tables
ove la gamba, vezzosamente
lievitando verso i bordi del top,
si trasforma in un ricciolo.
Tecnicamente non è che un
oggetto, dall'estetica quasi
brutalista in lamiera verniciata
ma il colore e questo dolce gesto
di poesia, lo trasformano in una
presenza che invita alla quiete
e al sogno.

Collection of small coffee tables
with a leg that daintily curls above
the edge of the top. technically
speaking it is just an object -
and quite a plain one at that -
made of lacquered metal,
but the use of colour and this
charming poetical gesture
transform it into a piece
that fosters peace and stimulates
the imagination.







driade BASALT



basalt

DESIGN _ FREDRIKSON STALLARD

Tavolino scultoreo e prezioso. Un frammento materico sostenuto da un supporto museale. Piano in cemento alleggerito con finitura a cera di colore grigio ardesia e struttura in trafilato d'acciaio con finitura oro lucido.

Scultural and precious small table. A fragmented piece hold up by a museum stand. Top in lightened concrete with wax finish late-gray color. Structure in drawn steel with polished gold finish.



zagazig
DESIGN _ DRIADELAB





Una collezione di tavoli bassi, pensati in set di due, in diverse misure che, con libertà, possono vivere singolarmente al centro di un living o ad affiancare le sedute. Le forme sono irregolari e movimentate, giocano su tre altezze e dimensioni diverse. Proprio come in Ziqqurat per ogni top sono previsti due pattern, realizzati in bi-laminato con grafica in stampa digitale, di gusto contemporaneo e molto precisi nella loro riconoscibilità: collage retrò, decori optical, texture che interpretano le trame suggerite dalla creatività della moda d'oggi. La struttura è realizzata in tondino d'acciaio verniciato in color oro. Questa scelta nostalgica, eppure così attuale, dona eleganza e preziosità all'insieme.

A collection of coffee tables in various sizes created as a set of two which can stand by themselves in the centre of the living room or be used as side tables, as desired. Their shapes are irregular and dynamic, available in three different heights and sizes. Just like the Ziqqurat cabinet, each top comes in two different patterns made of digital printed bilaminate with contemporary, very distinctive, designs: vintage collages, optical decors, textures that interpret the weaves suggested by the creativity of current trends. The frame is in gold-coloured tubular steel. This nostalgic yet trendy choice adds elegance and charm to these pieces.





waterfall

DESIGN _ FREDRIKSON STALLARD

Un coffee table può diventare un'opera qualora si riesca a prescindere dalle limitazioni tipologiche. Ne risulta una forma del tutto inedita, segnata da un importante, ed espressionistico, incavo al centro del piano.

Even a coffee table can become a piece of art if it can stand regardless of the typological limitations. The result is a completely new form, marked by an important, and expressionistic, depression in the center of the top.



portable atelier

DESIGN _ PHILIPPE NIGRO



Uno scrittoio leggero, di dimensioni contenute, con un piano a ribalta che accoglie laptop, fogli e cavi. Portapenne e contenitori in legno e metallo a personalizzare lo spazio con diverse forme e colori.

Uno sgabello regolabile che segue ovunque lo scrittoio o si muove autonomamente per sedute volanti e dinamiche.

Una mensola in legno e metallo, dotata di elementi scorrevoli ideale per arredare tavoli e scrivanie ritagliando ovunque uno spazio raccolto e personale. Sono questi i protagonisti di Portable Atelier.

A small, lightweight desk with a flap top that can hold a laptop, sheets of paper and wires. Pen holders and storage boxes in wood and metal are for personalising the space with different shapes and colours. An adjustable stool goes everywhere with the desk or can be moved independently for dynamic, improvised seating. A shelf made of wood and metal fitted with sliding elements is ideal for furnishing tables and desks to create a defined personal space anywhere. These are the features of Portable Atelier.



ping I, II

DESIGN _ GIUSEPPE CHIGIOTTI

Esistevano un tempo, nelle case, piccoli oggetti servizievoli. Per il fumo piuttosto che per il cucito, per servire piuttosto che per esporre: essi punteggiavano gli spazi dell'abitare. Giuseppe Chigiotti, nell'ideare "Ping", ripensa a quei periodi ormai trascorsi e tratteggia un servante declinato in due versioni: Ping I, caratterizzato dalla dimenticata funzione di svuota tasche, e Ping II, discreto piano d'appoggio per un bicchiere o un libro.

Ancient houses used to be full of many helpful small objects. For putting ashes rather than for sewing, to serve rather than to expose: they punctuated dwelling spaces. Giuseppe Chigiotti, by designing "Ping", thinks back to those times now passed, and creates a "servante" declined in two versions: Ping I, characterized by the function of empty pockets and Ping II, discrete surface for a glass or a book.

picapica

DESIGN _ KAZUYO SEJIMA



Dall'ò di Giotto in poi, quanti cerchi!
Ma anche prima, risalendo fino
all'invenzione della ruota.

Il piano del tavolino di Kazuyo Sejima
è perfetto e imperativo nella sua
semplicità, su quattro esili gambe.

From the o by Giotto onwards,
how many circles! But even before
that, going back to the invention
of the wheel. The table top is perfect
and imperative in its simplicity,
on four slender legs.





CONTENITORI E LIBRERIE

cabinets and bookcases

Ogni cosa in ordine: è una regola d'oro. Per farlo bisogna organizzarsi e organizzare lo spazio nell'interno dei contenitori, che siano essi mobili contenitore o librerie.

Le librerie Driade sono tutte freestanding, suddividono gli ambienti, arredandoli; pezzi dal design fortemente distintivo, pensati per accogliere libri e oggetti ma bellissimi anche vuoti.

Everything in order: it's the golden rule. To do this we need to organize the space inside the containers, whether they are cabinets and storage furniture or bookcases.

Driade's libraries are freestanding, separate spaces, decorating. Furniture with an unique design, meant to contain books and objects, beautiful even empty.

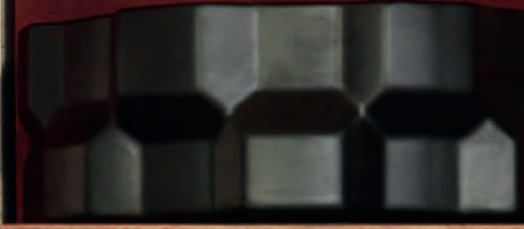



love

DESIGN _ FABIO NOVEMBRE

«Amore è scegliersi a scatola chiusa, avvolti da un alone di mistero. Amore è un fedele custode di sogni condivisi, un contenitore di possibilità» Fabio Novembre

Con la sua forma caratterizzante e tutta da scoprire, la madia LOVE (cabinet) costituisce un manifesto espressivo, un poster bidimensionale che parla d'amore. Dal connubio tra estetica e funzione, le linee diventano tridimensionali, il foglio si estrude diventando contenitore e le lettere escono dal foglio generando delle maniglie, elementi versatili e disponibili in vari colori.

«Love is choosing oneself in a closed box, wrapped in an aura of mystery. Love is a faithful guardian of shared dreams, a container of possibilities» Fabio Novembre

With its characterizing and intriguing shape, the LOVE cabinet is an expressive bill, a two-dimensional poster that speaks of love. The union between aesthetics and function makes the lines three-dimensional, extrudes the sheet that becomes a container and pulls letters out of the sheet generating handles, versatile elements, available in various colors.





hidalgo

DESIGN _ DRIADELAB

Per un arredamento d'interni unico e originale, eccentrico e allo stesso tempo estremamente elegante, Hidalgo è una credenza verticale dall'insolito design, portavoce dei codici e dello stile Driade, per una casa contemporanea. Hidalgo è un contenitore anomalo: anomalo nella forma, anomalo nel concetto, anomalo nella sua staticità. Un oggetto straordinario che, se pur funzionale, ha nella sua presenza il carattere distintivo e peculiare che lo rende più vicino ad una scultura che ad un mobile. Il cabinet presenta una struttura di forma irregolare realizzata in multistrato curvato, tre ante a battente con sistema di apertura push-pull e ripiani interni fissi, Hidalgo è un contenitore dalla notevole capienza interna dove è possibile conservare una quantità di oggetti.

For a unique and original interior design, eccentric and at the same time extremely elegant, Hidalgo is a vertical sideboard with an unusual design, spokesperson for the Driade codes and style, for a contemporary home. Hidalgo is an anomalous cabinet: anomalous in shape, anomalous in concept, anomalous in its static nature. An extraordinary object that, although functional, has in its presence the distinctive and peculiar character that makes it closer to a sculpture than to a piece of furniture. A cabinet with an irregularly shaped structure made of curved plywood, three hinged doors with push-pull opening system and fixed internal shelves, Hidalgo has a considerable internal capacity, where it is possible to store a number of objects.









ziqqurat

DESIGN _ DRIADELAB

Quale potrebbe essere, oggi, il progetto di un contenitore?
Questo il quesito che DriadeLab, osservatorio di Driade sui modi del vivere contemporaneo, si è posto come punto di partenza per la ricerca.

Esito è Ziqqurat, un cabinet che si compone di box differenti i quali, sovrapposti, ne delineano una forma sempre differente. Tale sistema, a tutti gli effetti costruttivo, permette composizioni di tre diverse dimensioni, adattandosi agli spazi dell'abitare.

Non è dunque un caso l'ispirazione all'antica piramide sumera, leitmotiv così forte del progetto tanto da scegliere di citarne anche il nome. Le forme ed i volumi offrono un carattere unico a questo speciale oggetto d'arredo.

What could the design of a storage cabinet be like today?
This is the question DriadeLab, Driade's observatory on contemporary lifestyles, asked itself when it started to research into this project. The result was Ziqqurat: a cabinet made up of different boxes that can be piled up to create everchanging forms. This system, constructive in all respects, can be used to create arrangements of three different sizes depending on the space available. The project's source of inspiration, ancient sumerian pyramids, is no random choice: it is such a strong theme that it even gave its name to the cabinet.

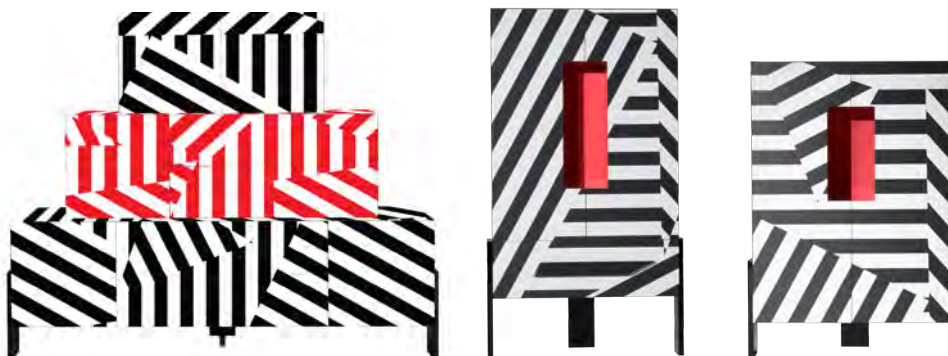

















ercole e afrodite

DESIGN _ DRIADELAB

Combinazione sorprendente tra arte decorativa e linguaggio storico, questo contenitore dalle forme classiche e scultoree si inserisce come oggetto d'arredo prezioso in un ambiente eclettico e sofisticato.

Unexpected combination of decorative art and historic language, this storage units with its classic sculpted shapes becomes a precious furnishing item in an eclectic and sophisticated setting.



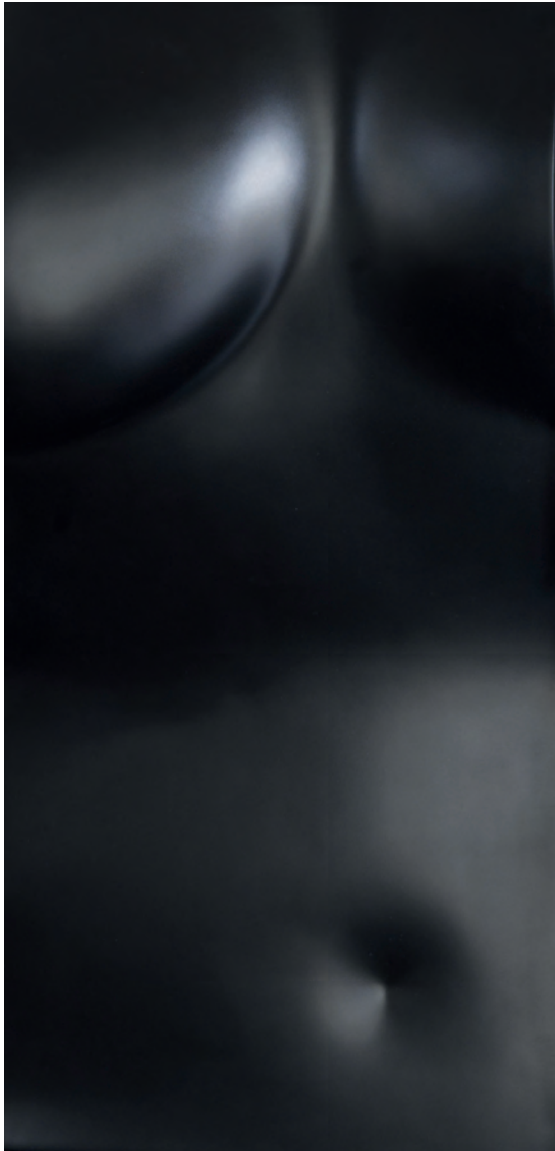









“Canova imagined that his Venus had been caught unawares in the nude and he gave her a marble veil to hide herself from indiscrete eyes. I add a succession of wooden shelves that cross the most private parts of her body to camouflage her in the midst of books and other objects. A four-handed job performed at different moments in time by two italians who are particularly fascinated by the epitome of female beauty: Venus.”

FABIO NOVEMBRE

venus

DESIGN _ FABIO NOVEMBRE



Novembre trae ispirazione dalle casse lignee utilizzate dai musei per il trasporto delle statue trasformandole in poetico oggetto di design. La categoria dice che si tratta di una libreria ma uno sguardo differente potrebbe trovare in Venus la statua di una dea. Entrambe le letture sono corrette e si fondono fra loro. Venus è questo: arte, la possibilità di godere della sua bellezza, e funzione, a cui il design mai può sottrarsi.

Novembre draws his inspiration from the wooden crates used by museums to transport statues and transforms them into graceful design objects. It has been classified as a bookcase but a different point of view may regard Venus as the statue of a goddess. Both opinions are correct and interconnected. Venus is both things: art i.e. the possibility of enjoying its beauty, and function, an essential part of design.





zigzag

DESIGN _ KONSTANTIN GRCIC

La struttura a Zigzag dello scaffale è semplice e fresca; la paletta di colori per le parti metalliche - nero, bianco, bronzo e acciaio lucido - è completata da due tipologie di ripiani in legno, in rovere e in noce Canaletto.



The shelf's Zigzag shaped structure is simple and fresh; the color palette for the metal work - black, white, bronze and polished stainless steel - is complemented by two kinds of wooden shelves, oak and Canaletto walnut.





WHAT MODERN WAS
WITH
NEW FORMS



virgo

DESIGN _ XAVIER LUST



Virgo è una struttura “in tensione” che prende le sembianze tipologiche di una libreria, ma in realtà ci porta a ragionare sui rapporti tra superfici concave e superfici convesse, sull’energia della corda tesa nell’arco. La forma sculturale assunta da Virgo ne consente l’uso non solo a parete, ma soprattutto al centro dello spazio.

Virgo is a “living” structure which becomes a bookcase but, in fact, leads us to think about concave and convex surfaces relation as about the energy of a tightrope. The sculptural form of Virgo makes it usable both on the wall and, above all, as centre-room.



COMPLEMENTI D'ARREDO

furnishing accessories

Magia e stupore contraddistinguono i complementi d'arredo Driade:
lampade evanescenti magicamente sospese, specchi originali,
tappeti decorativi, paraventi personaggio, appendiabiti poetici.
Inaspettati complementi d'arredo dal forte carattere in grado
di personalizzare ogni ambiente.

Magic and surprise are the essence of Driade accessories:
evanescent lighting magically suspended, original mirrors,
decorative carpets, screens, poetic coat hangers, unexpected plant holders.
Furnishing accessories with a strong personality,
perfect to personalize every ambient.



nemo miniatura flocced

DESIGN _ FABIO NOVEMBRE

Nemo, l'iconica maschera-poltrona nata dall'estro creativo di Fabio Novembre nel 2010, è diventata anche un oggetto in miniatura che rappresenta il design di Driade. Già proposta nella versione lucida in polietilene nei colori bianco, nero, rosso, grigio e metallizzati oro o argento, Mini Nemo è oggi disponibile in un'inedita versione floccata che, assieme alla personalizzazione su targhetta in acciaio, la rendono un oggetto prezioso e particolarmente adatto per un regalo di design.

Nemo, the iconic mask-armchair designed by Fabio Novembre' in 2010, has also become a miniature object representing Driade's design. Already available in the glossy polyethylene version in white, black, red, grey and metallic gold or silver, Mini Nemo is now available in a brand new flocced version which, together with the personalisation on a steel plaque, makes it a precious object and particularly suitable for a designer gift.







nemo miniatura
...or simply mini nemo?

DESIGN _ FABIO NOVBRE





hanahana

DESIGN _ KAZUYO SEJIMA

La semplicità e la freschezza, tipiche dei progetti di Kazuyo Sejima, sono tutte in questo poetico oggetto: un esile alberello i cui rami salgono al cielo come una preghiera. E con un'offerta di fiori.

The simplicity and freshness typical of the projects by Kazuyo Sejima, are all in this poetic object: a slender tree whose branches rise to heaven like a prayer. And with an offering of flowers.



acate

DESIGN _ BOREK SIPEK



Ecco l'imitazione poetica di una natura capricciosa: virgulti che si abbracciano come sospinti da una passione d'amore, che li intreccia fra loro legandoli per sempre.

Here it is the poetic imitation of a capricious nature: shoots that become entangled as driven by the passion of love, which weaves them by tying them forever.





miro

DESIGN _ FRANCESCO BOLIS



Un paravento-opera che,
inaspettatamente, sul fronte
posteriore propone uno specchio
“a trittico” e un’immagine...
Galleria Vittorio Emanuele.

An artistic screen that offers,
unexpectedly, a “trptych” mirror
on the rear side designed and one
image... Galleria Vittorio Emanuele.

archipelago

DESIGN _ FREDRIKSON STALLARD

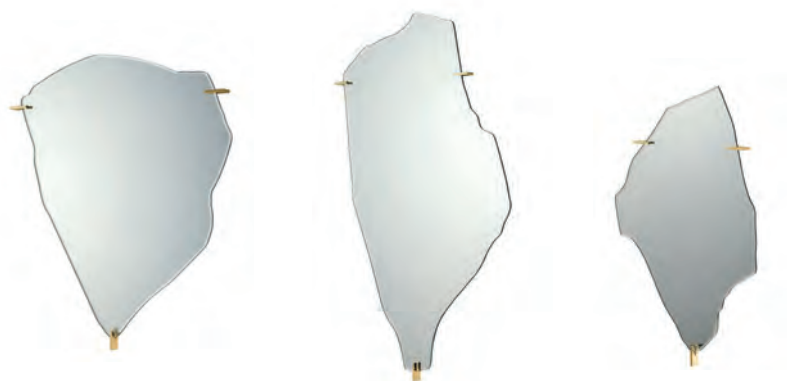

Tre specchi dai contorni frastagliati a evocare i profili irregolari di un'isola. Perfetti per ogni ambiente della casa, gli specchi possono essere proposti singolarmente o, a sottolinearne la forza espressiva, in un'armonica composizione.

Three mirrors with jagged frames that remind one of the irregular outlines of an island. Perfect for any room in the home. These mirrors can be used on their own or to form a harmonious composition, in order to highlight their expressive impact.



egeso

DESIGN _ BERTOCCO & LOCATELLI

Erbe di campo, mosse da un vento gentile,
fanno da cornice, leggera e delicata, a uno
specchio quadrato. dove immergersi per un
attimo in una fresca natura.

Wild herbs, moved by a delicate breeze,
frame, lightly and gently, a square mirror,
where to dive, for a moment, into a fresh
nature.





taylor and snijder bird

DESIGN _ ED ANNINK

Non sembra di ascoltare un lontano
e sussurrato cinguettio? Un'illusione
seducente, inaspettata e garbata.

Doesn't it seem to hear a far and whispered
chirping? A seductive illusion,
unexpected and delicate.





osmond

DESIGN _ PIETRO DEROSI

Un piano inclinato, ritagliato in una superficie specchiata più grande, che a sua volta diventa cornice, crea un effetto magico. L'immagine che ne risulta si frantuma e mette in evidenza dettagli nascosti.

An inclined plane, cut eccentrically on a mirrored larger surface, which becomes the total frame, creates a magical effect. The resulting image is shattered and highlights hidden details.





erbale

DESIGN _ BECCELLI, BORTOLANI, MAFFEI

Erbale è senz'altro uno dei progetti più longevi nel catalogo Diade. Ideato nel 1995 rappresenta in realtà una “invenzione di tipologia”: mai infatti si era vista una “tenda-paravento” costruita con sacche in plastica alternate per il contenimento di piante e acqua. Erbale è, tra l'altro, divenuto nel tempo uno dei simboli della affermazione di una nuova generazione di designer italiani.

Erbale is definitely one of the longest lasting projects in Diade catalog. Designed in 1995, it was actually the “invention of a typology”, as nobody had never thought before to a “screen-tent” constructed with plastic bags to contain plants and water. Erbale has also become one of the symbol of the rising italian designers' new generation.





POLTRONE E DIVANI

armchairs and sofas

I divani e le poltrone Driade si contraddistinguono per la forza e l'unicità delle loro caratteristiche; eclettici e giocosi ma allo stesso tempo eleganti e senza tempo sono protagonisti degli ambienti che animano. Sistemi componibili e pezzi singoli, chaise longue classiche e poltrone personaggio popolano il vasto catalogo Driade indoor e outdoor.

Comodi e confortevoli sono ideali per il relax ed i momenti conviviali.

Driade sofas and armchairs are eclectic and joyful, elegant and timeless; they are protagonists of their inhabited spaces. Modular systems and unique pieces, classic chaise longues and protagonist armchairs populate the Driade catalogue. Comfortable pieces, perfect for relax and convivial moments.





“In a room for the well-being
many elements called “furniture”
are necessary that actually
once set remain “fixed”.
I always reject the tendency
to overload the space;
therefore I have always worked
to the limit of need”.

KATERYNA SOKOLOVA

tottori

DESIGN _ KATERYNA SOKOLOVA

Tottori è una collezione di sedute e tavolini dalle forme senza tempo, dalla silhouette seducente e dal carattere audace. Ispirata al film d'animazione giapponese "Il mio vicino Totoro", scritto e diretto da Hayao Miyazaki, la collezione di arredi Tottori conferisce un'atmosfera intima e calda all'ambiente domestico grazie all'aspetto accogliente e morbido dei suoi componenti.

Tottori is a seating and coffee tables collection with timeless shapes, cute silhouette and bold character. Called after the Japanese animation film "My Neighbor Totoro", written and directed by Hayao Miyazaki, the Tottori furniture collection has a friendly and soft silhouette that brings a cozy mood in the house.









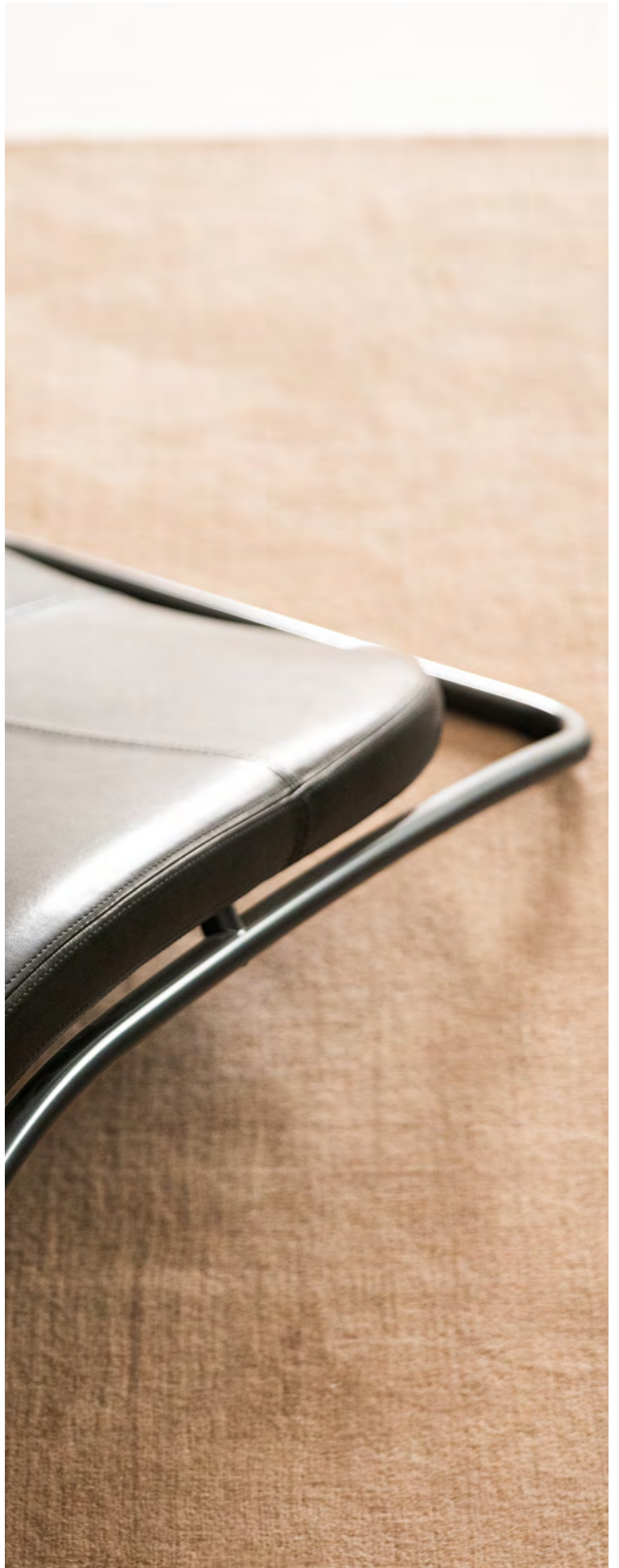

wireflow

DESIGN _ MICHEL ROJKIND

Abbiamo progettato la chaise longue Wireflow creando un involucro morbido e flessibile, evocando linee semplici e fluide con particolare attenzione all'ergonomia e al comfort. L'intenzione del design del telaio metallico è di creare una geometria organica continua che scorre lungo un percorso simile all'energia che scorre in tutto il corpo. Le cuciture in pelle riflettono le isocurve della superficie che sono rappresentate digitalmente nella cucitura artigianale di alta qualità. L'ispirazione deriva dal concetto di movimento sottile che si sviluppa nel tempo. Il design esprime semplicità, dinamismo, leggerezza e continuità.

We designed the Wireflow chaise longue creating a soft and flexible shell, evoking simple and fluid lines with particular emphasis on ergonomics and comfort. The intention of the metal frame design is to create a continuous organic geometry that flows along a path like energy flowing throughout the body. The leather seams reflect the digitally designed isocurves of the surface that are represented in high quality handcraft stitching. The inspiration for the Wireflow chaise longue came from the concept of subtle movement unfolding in time. The design expresses simplicity, dynamism, lightness and continuity.





ENZO MARI CURATED
BY HANS ULRICH OBRIST

ITALIANA
1950-1970

italic

DESIGN _ FABIO NOVEMBRE

Italic, o corsivo, è uno stile di carattere tipografico che nasce per imitare la scrittura a mano. La definizione Italic è un tributo ad Aldo Manuzio, l'uomo che nel 1500 ha democratizzato la cultura inventando il libro stampato. La poltrona Italic nasce da queste premesse: una magistrale dimostrazione della manualità degli artigiani di driade e un omaggio al genio italico. Come un vettore di elementi assemblati, a metà strada tra una poltrona e una piccola architettura, che indica la direzione di Driade per i prossimi anni.

Italic, or cursive, is a typeface that was created to imitate handwriting. The Italic definition is a tribute to Aldo Manuzio, the man who in 1500 democratized culture by inventing the printed book. The Italic armchair is born from these premises: a masterly demonstration of craftsmanship of driade artisans and a tribute to the Italian genius. As a carrier of assembled elements, halfway between an armchair and a small architecture, which indicates the direction of Driade for the coming years.





lou read

DESIGN _ PHILIPPE STARCK WITH EUGENI QUITLLET



Una poltrona personaggio, dalla sagoma organica.
L'inaspettato confort è dato dalla perfetta ergonomia
del manufatto.

An armchair/character with an organic outline.
The unexpected comfort is given by its perfect ergonomics.









lou speak

DESIGN _ PHILIPPE STARCK

Quando siedi su una Lou Speak sei costretto ad elevare il livello della conversazione. Se non lo fai, la tua poltrona risulterà più elegante di te. Philippe Starck. Si tratta dell'ampliamento della famiglia Lou. Ora è il momento di parlare. Questa poltrona girevole, comoda e avvolgente, segue infatti Lou Read e Lou Eat.

When you sit on a Lou Speak you are obliged to raise your level of conversation. If you don't, your chair will look more elegant than you do. Philippe Starck. This is an addition to the Lou family. It's now time to talk. this comfortable, cocooning, swivel chair has just shown up after Lou Read and Lou Eat.









moon

DESIGN _ LUDOVICA + ROBERTO PALOMBA

Per il progetto Moon,
la scocca laccata o rivestita in pelle poggia
su di un frame metallico dalla costruzione
leggerissima che accoglie confortevolmente
il corpo con seduzione e iconicità
per un sottile gioco tra lo stupire
ed il voler passare inosservati.

The lacquered shell of the Moon,
sits on a very light
metal frame or leather covered
and comfortably pampers your body
in a subtle, seductive interplay
of amazement and understated iconic beauty.







cinemascope

DESIGN _ PHILIPPE STARCK



“If all presidents and kings in the world had an exceptionally comfortable armchair like Cinemascope, can you imagine how their ideas, conversations and decisions would change? Cinemascope is the armchair that can save the world.”

PHILIPPE STARCK









vigilius

DESIGN _ MATTEO THUN & ANTONIO RODRIGUEZ



Comode sedute dal design classico
e fortemente decorativo, perfette per arredare
angoli contenuti così come ampi ambienti.

The cosy seats have a classic and very decorative
design and are just perfect to furnish narrow
corners or large spaces alike.



ten

DESIGN _ NAOTO FUKASAWA



La poltrona Ten, avvolgente e confortevole,
si adatta armoniosamente ad ogni ambiente,
dal classico al metropolitano.

The armchair Ten, cozy and comfortable,
harmoniously blends into all interiors,
from classical to metropolitan.







ENZO MARI CURATED
BY HANS ULRICH OBRIST



lisa

DESIGN _ LAUDANI & ROMANELLI

La poltrona diviene una poltroncina ovvero un “luogo individuale”, un “passepartout” per riscoprire riti dimenticati: poltroncine attorno al tavolo, nelle camere da letto o negli ingressi.

The armchair becomes an easychair and a “place for the individual”, a “passepartout” to forgotten customs: easychairs around tables, in bedrooms or in vestibules.





s. marco

DESIGN _ MATTEO THUN & ANTONIO RODRIGUEZ

S.Marco e S.Marco Lounge raccontano
una cultura dell'abitare fatta di convivialità
e di accoglienza.

S.Marco and S.Marco Lounge evoke
a sedimented "living culture"
made of conviviality and hospitality.



s. marco lounge

DESIGN _ MATTEO THUN & ANTONIO RODRIGUEZ





“A rare example of energy,
courage and diversity.
A truly unusual combination
of thought and manual skill.
In short, it is an example of how
it is possible to bend the industry,
each different industry in a different way,
to our own vision of the world
and to the result we want to obtain.”

PATRICIA URQUIOLA



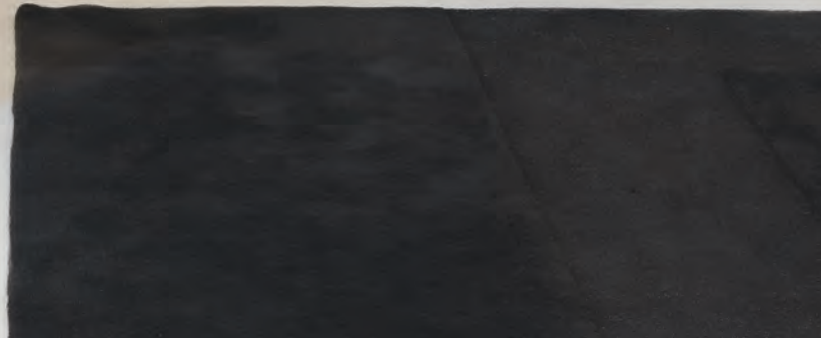

pavo

pavo real

DESIGN _ PATRICIA URQUIOLA

Patricia Urquiola compie una raffinata operazione di rivisitazione delle grandi poltrone in rattan e midollino diffuse nei paesi del sud-est asiatico.

I volumi si dilatano, gli intrecci si raddoppiano, il decoro compare inaspettato con la seducente tattilità dei materiali naturali.



Patricia Urquiola makes a sophisticated review operation of those big rattan and cane armchairs so diffused in south-eastern Asia.

Volumes expand, braids are doubled, patterns appear unexpectedly with the seductive tactility of natural materials.

suki

DESIGN _ TOYO ITO

Maestro dell'architettura, il giapponese Ito ha proposto, nel tempo, poche straordinarie prove da designer. La poltrona Suki, progettata nel 1987, è una di queste: oggetto misterioso per l'adozione di un doppio filare di rete d'acciaio distanziato da numerose molle.

As a master in architecture, the Japanese Ito has proposed few but extraordinary design works. Suki armchair, designed in 1987, is one of them: an object made mysterious by the use of a double steel mesh row intersected by many springs.







“I am trying to counter the fixity
of architectures, their stolidity,
with elements that give
an ineffable immaterial quality.”

TOYO ITO



wow, wow low back

DESIGN _ PHILIPPE STARCK

Wow è un sistema componibile estremamente ricco. Ai divani a due e tre posti si affiancano chaise longues ed elementi angolari che permettono di realizzare molteplici combinazioni. La forma segue la funzione primaria: la comodità.

Wow is a luxurious modular system. Besides two-seat and three-seat sofas, it includes chaise longues and corner elements conceived to define multiple layouts. The shape mirrors its primary function: comfort.



L'alto e avvolgente schienale
e l'imbottitura in gomme
poliuretaniche e piuma d'oca
garantiscono la massima comodità.
Questa è la garanzia del wow effect!

High enveloping backrest
and polyurethane and goose down
padding ensure an extreme comfort.
This is the wow effect!







“One night I had a dream or, rather,
a memory surfaced in my mind.
I recall the delightful times
when sofas were comfortable,
and we shouted ‘wow,’ while leaping on them.
I felt nostalgic for the past.
And I thought that it was not bad after all,
so I created Wow,
the sofa that embraces you.”

PHILIPPE STARCK





fenix

DESIGN _ LUDOVICA + ROBERTO PALOMBA

Divano componibile in cui un'esile struttura metallica enfatizza il senso di sospensione da terra. La versione con terminali presenta una grande penisola dalla forma garbatamente asimmetrica.

Sectional sofa which thin metal structure emphasises the sense of suspension from the ground. The version with terminals presents a great peninsula from the gracefully asymmetric shape.







lirico

DESIGN _ LUDOVICA + ROBERTO PALOMBA

Lirico e Lirica.

Un sistema modulare e una poltroncina progettati dai designer Ludovica Serafini + Roberto Palomba.

In questo caso, il duo si concentra sul tema della leggerezza, cercando forme sospese e lineari perché sembrano fluttuare, ottenuta con l'espedito del piede in fusione, dettaglio che caratterizza con grazia la personalità del divano.

Il comfort di Lirico si rintraccia nella capacità di poter assemblare pochi elementi essenziali il cui dettaglio è sapientemente studiato.

Lirico and Lirica.

A modular system and a chair designed by Ludovica Serafini + Roberto Palomba. In this case, the duo has focused on the theme of lightness, looking for floating, linear shapes that appear to be fluctuating above the floor.

They have achieved this by means of the masterly use of cast feet: a graceful, distinguishing detail of this sofa's personality.

Lirico's comfort stems from the fact that it is made up of just a few, essential parts with cleverly-devised details.













lirica

DESIGN _ LUDOVICA + ROBERTO PALOMBA





my last **hotel**, or my next **home**. **hall**

DESIGN _ RODOLFO DORDONI

Hall rilette il classico capitonné da club inglese riportandolo ad una dimensione di comfort domestico.



Hall makes over the classic quilted upholstery typical of British country club sofas to adapt it the requirements of domestic comfort.





neil

DESIGN _ LUDOVICA + ROBERTO PALOMBA

Neil Armstrong, saltellando in completa assenza di gravità sul terreno lunare ha consacrato per sempre l'idea di leggerezza.

È proprio al concetto "ungravity" a cui si sono ispirati Ludovica Serafini + Roberto Palomba per il nuovo divano Neil per Driade.

Neil sofa si contraddistingue per la sua semplicità e per la sua compattezza, contiene un'anima assolutamente inaspettata, grazie alle imbottiture elastiche che al loro interno racchiudono un telaio tecnologico che rende flessibili sia i braccioli che gli schienali su cui potersi appoggiare in completo relax, senza stravolgere la struttura del divano.

Nuovo intimo rifugio con un'estrema comodità di seduta sulla quale anche un semplice sonnellino diventa una passeggiata sulla luna.

When he walked on the moon in complete absence of gravity, Neil Armstrong forever consecrated the concept of lightness.

For the new Neil sofa designed for Driade, Ludovica Serafini + Roberto Palomba drew their inspiration from the same concept of weightlessness.

This sofa stands out for its simple lines and compactness and contains a totally unexpected soul: without altering the structure of the sofa, its elastic padding encloses a technological framework that makes the arm and backrests flexible, favouring complete relaxation. A new, intimate refuge featuring extremely comfortable seats on which even a small nap comes as easily as walking on the moon.







dracole









28

29

27

30

31

32



33 cuscini

DESIGN _ PAOLO RIZZATTO

Divano gioioso e dal design unico.
L'imbottito torna all'origine del suo percorso evolutivo quando altro non era che una serie di cuscini appoggiati su una panca.
Il designer "blocca" i cuscini, li rende "strutturali" e inventa una nuova forma di macro capitonné ove ogni singolo modulo conserva una precisa identità.

Joyful sofa with unique design.
The sofa gets back to the origin when it was nothing more than a lot of pillows leaning on a bench. The designer draws a new form of macro capitonné where each module retains its own identity.







leeon soft

DESIGN _ LUDOVICA + ROBERTO PALOMBA

Divano decorativo ed elegante, si contraddistingue per il damier della trapuntatura e per i supporti puntuti. Ne discende un progetto ampiamente declinato, utilizzabile in ambienti pubblici e privati.



Decorative and elegant sofa, characterized by the damier decoration and the straight cast-aluminum structure. The result is an extended project, meant to be used both in private and public areas.







rever

DESIGN _ LUDOVICA + ROBERTO PALOMBA



Rever è il prodotto young della collezione Driade. Morbido, generoso nelle curve e nelle proporzioni. Un originale incastro di braccioli, caratteristica fondamentale del sofà, e particolare attenzione al dettaglio: un bordo leggermente imbottito che sembra rubato all'immaginario della moda, poiché ispirato ai baveri delle giacche e alle pattine delle tasche. Rever è un divano estremamente versatile. Le ampie dormeuse e i comodi pouf lo rendono piacevolmente adatto alla convivialità e al gioco.

Rever features plump, generous curves and proportions. The original way the armrests are fitted - a fundamental feature of this sofa - is paired with special attention to detail: the slightly padded edge looks as if it comes from a fashion house because it is inspired by the lapel of jackets and the flap of pockets. Rever is an extremely versatile sofa. The large day beds and the comfortable poufs make it perfect for moments of enjoyable togetherness and play.



“I have always perceived
a touch of the French culture
in the eclectic identity of way
of mixing different styles
of furniture, contemporary objects”.

ALBERTO LIEVORE







verlaine

DESIGN _ LIEVORE ALTHERR MOLINA

Grazie alla sua affascinante silhouette, Verlaine diviene il principale dettaglio estetico del living room, seduce gli occhi, cattura l'attenzione, invita alla prova.

Verlaine fascinating silhouette is an irresistible attraction inviting the viewer to appreciate the comfortable seat. Verlaine becomes the main aesthetic detail of the living room; it entices the eyes and grabs the attention.

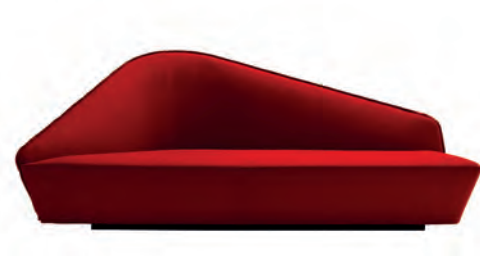



elisa

DESIGN _ ENZO MARI

Divano dal design minimale ed elegante,
sintesi di leggerezza e comfort.

Sofa with an elegant and minimal design,
perfect blend of lightness and comfort.









mod

DESIGN _ LUDOVICA + ROBERTO PALOMBA



La semplicità è, per lo studio Palomba + Serafini, talvolta, un'intuizione ove la geometria rigorosa delle forme si rinnova, senza abbandonare i principi dell'eleganza più pura e il minimalismo più essenziale.

Le linee di questo divano componibile non sono mai interrotte da elementi che tradizionalmente separano; l'ampia seduta è sorretta dal piede incorporato nella struttura del divano stesso, un'innovazione che appare ovvia, in realtà inedita.

For the Palomba + Serafini studio, simplicity is sometimes an intuition in which the rigorous geometry of forms is renewed without abandoning the principles of the purest elegance and of the most essential minimalism. The lines of this modular sofa are never interrupted by elements that traditionally create a separation; the large seat stands on feet that are integrated in the frame of the sofa itself, an innovation that may seem obvious, but that is really brand new.





mody

DESIGN _ LUDOVICA + ROBERTO PALOMBA



La poltroncina Mody completa il progetto Mod. Ha carattere deciso e una personalità attraente. Perfetta per l'intimità domestica come per la convivialità degli spazi pubblici.

Mody completes the Mod project with a bold character and an appealing personality. Perfect for the domestic intimacy as well as for the public spaces.



outdoor



in or out







nemo

DESIGN _ FABIO NOVEMBRE

Fabio Novembre utilizza il furniture design per raccontare delle storie. Storie intense e coinvolgenti ove sovente protagonista è la figura umana.

Una figura umana capace di farsi astratta e universale, capace di proporre una bellezza mitizzata come succedeva con l'arte greca. Così in Nemo un volto dalle sembianze classiche viene scavato per creare uno spazio abitabile. Una testa-poltrona quindi, vissuta dall'interno e che, come una maschera, cela e contemporaneamente rivela il suo abitante.

Fabio Novembre uses furniture design to tell intense and fascinating stories in which the protagonist is often the human figure.

This human figure is capable of becoming abstract and universal, able to propose a mythic beauty as occurred in Greek art. So that Nemo, a face with classic features, is hollowed out to create an inhabitable space. The result is a head-armchair to be lived from the inside. Like a mask, it simultaneously conceals and reveals its inhabitant.











roly poly

DESIGN _ FAYE TOOGOOD

La Collezione Roly Poly, composta da poltroncina e divanetto, racchiude in sé i concetti di arredamento e scultura rappresentando così la filosofia di Driade in modo perfetto. La caratteristica di questi complementi di arredo monoblocco è la forma a ciotola della seduta, arrotondata e accogliente, con gambe cilindriche e forme delicatamente lineari che le conferiscono un aspetto rassicurante e massiccio. Realizzata in polietilene mediante stampaggio rotazionale, il sedile basso è stato arricchito con soffici cuscini imbottiti che si annidano nella sua forma curva per una coinvolgente esperienza di seduta. Poltroncina e divano sono disponibili in una varietà di colori per completare qualsiasi tipo di decorazione interna o esterna.

The Roly Poly Collection, consisting of an armchair and a sofa, embodies the concepts of furniture and sculpture, thus representing the philosophy of Driade in a perfect way. The characteristic of these monobloc furnishing accessories is the bowl shape of the seat, rounded and welcoming, with cylindrical legs and delicately linear shapes that give it a reassuring and massive look. Made of rotationally molded polyethylene, the low seat has been enriched with soft padded cushions that nestle in its curved shape for an engaging sitting experience. Armchair and sofa are available in a variety of colors to complement any type of interior or exterior decoration.









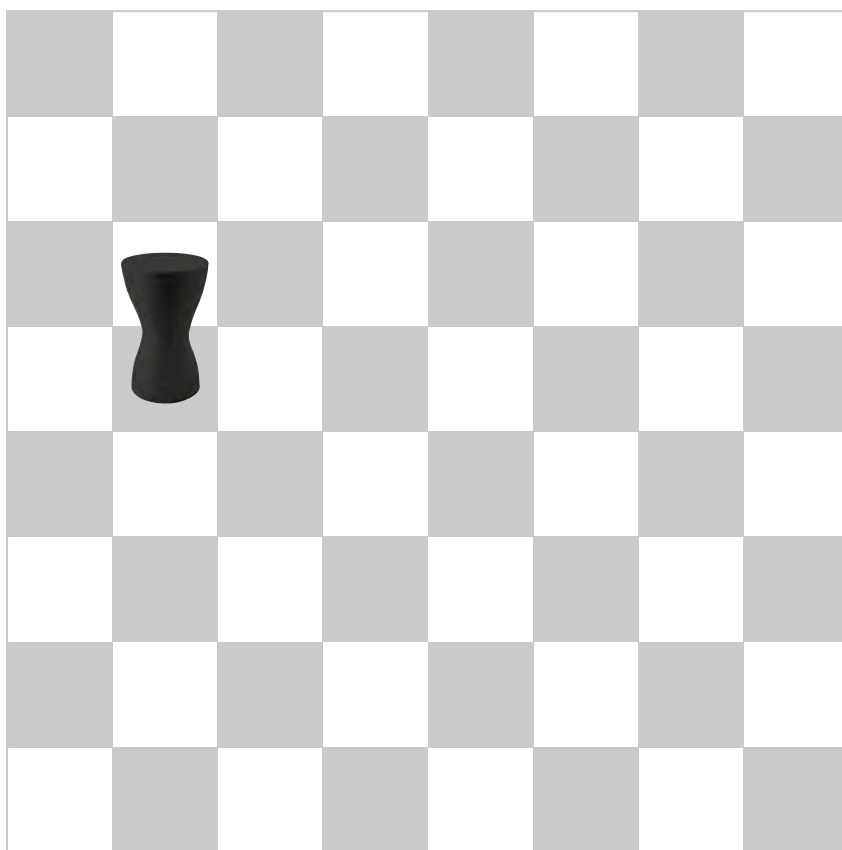

tokyo-pop

DESIGN _ TOKUJIN YOSHIOKA



Il divano, la poltrona e soprattutto la chaise longue e lo sgabello, lontani dalla banalità della plastica, sono vere e proprie sculture. Forme indimenticabili e inusitate.

The sofa, the armchair and above all the chaise longue and the stool, far from the banality of rotational molding are true sculptures. Unforgettable and unusual forms.











pliè
grand pliè
piaffè

DESIGN _ LUDOVICA + ROBERTO PALOMBA

Un divano da esterno, disegnato
“per la conversazione”, arte antica e nobilissima.
Un divano sul quale ognuno può trovare
la sua profondità di seduta e la sua posizione
ideale: più composta o più dolcemente rilassata,
a seconda del temperamento o delle occasioni
della giornata.



An outdoor sofa designed for the ancient
and very noble art of conversation.
In this sofa everyone can find his ideal depth
of seating position and posture: more composed
or more gently relaxed, depending on one's
temperament or the circumstances of the day.







mt1 mt2 mt3

DESIGN _ RON ARAD



“MT”, sigla che denomina questi pezzi progettati da Ron Arad, si pronuncia in lingua inglese “empty” vale a dire “vuoto”. Il vuoto è l’elemento caratterizzante di questo progetto. Il volume viene scavato e presenta provocatoriamente il suo interno, finito in rosso o nero.

“MT”, the acronym defining this collection designed by Ron Arad, in English is pronounced “empty” that means “vacuum”. Emptiness is really the key element of this project. The volume is hollowed and presents provocatively its interior, finished in red or black color.







mingx

DESIGN _ KONSTANTIN GRČIČ

Sedia, poltrona, poltroncina
e sgabelli caratterizzati dal profilo
in tubolare.

Seduta con cuscino per l'outdoor.
Proposta nei colori bronzo, nero
e arancio.

Chair, armchair, easychair,
and stools characterized by a tubular
profile. Cushion seat for outdoor.
Colors: orange, bronze and black.







elisa

DESIGN _ ENZO MARI

Divano dal design minimale ed elegante è perfetto per arredare patii, terrazze e giardini con un tocco di leggerezza.

Sofa with an elegant and minimal design, is perfect for decorating patios, terraces and gardens with a touch of lightness.







sissi

DESIGN _ LUDOVICA + ROBERTO PALOMBA

È un progetto moderno che ammicca sfrontato al passato e al mondo femminile. Gli anelli che si fondono sembrano piegati a mano e le loro sensuali connessioni fanno di Sissi un oggetto raffinato e scultoreo, proprio come la sedia viennese per eccellenza, famosa per le sue curvature in legno.

Its modern design winks cheekily at the past and at the female world. The merging and intersecting rings look as if they have been bent by hand and are linked in such a sensual way as to turn Sissi into a refined and sculptural piece, just like the ultimate Viennese chair - famous for its wooden curves - it is reminiscent of.









pip-e

DESIGN _ PHILIPPE STARCK, EUGENI QUITLLET

In Pip-e la successione degli elementi orizzontali, che creano seduta e schienale, assume una valenza fortemente chiaroscurale e prosegue, in modo inaspettato, ad accompagnare la curvatura interna del ginocchio.
Varianti: sedia e poltroncina.

The sequence of horizontal elements which creates the seat and the back definitely takes on a strong chiaroscuro and accompanies the bending of the knees.
Versions: chair and armchair.









toy

DESIGN _ PHILIPPE STARCK



Una poltroncina volutamente astratta nella sua composizione e, proprio per questo, confortevole in modo imprevedibile. Apparentemente scavata in un blocco, Toy parla un linguaggio di spigoli vivi e larghi piani che la rendono diversa dalle altre sedie in polipropilene stampato oggi disponibili sul mercato. In questa sua connotazione Toy appare unica persino all'interno del corpus progettuale di Philippe Starck.

A chair deliberately abstract in its composition and, for this reason, comfortable in unpredictable ways. Seemingly carved into a block, Toy speaks a language of sharp and broad planes that make it different from other molded polypropylene chairs. In this connotation Toy is unique even within the design corpus of Philippe Starck.

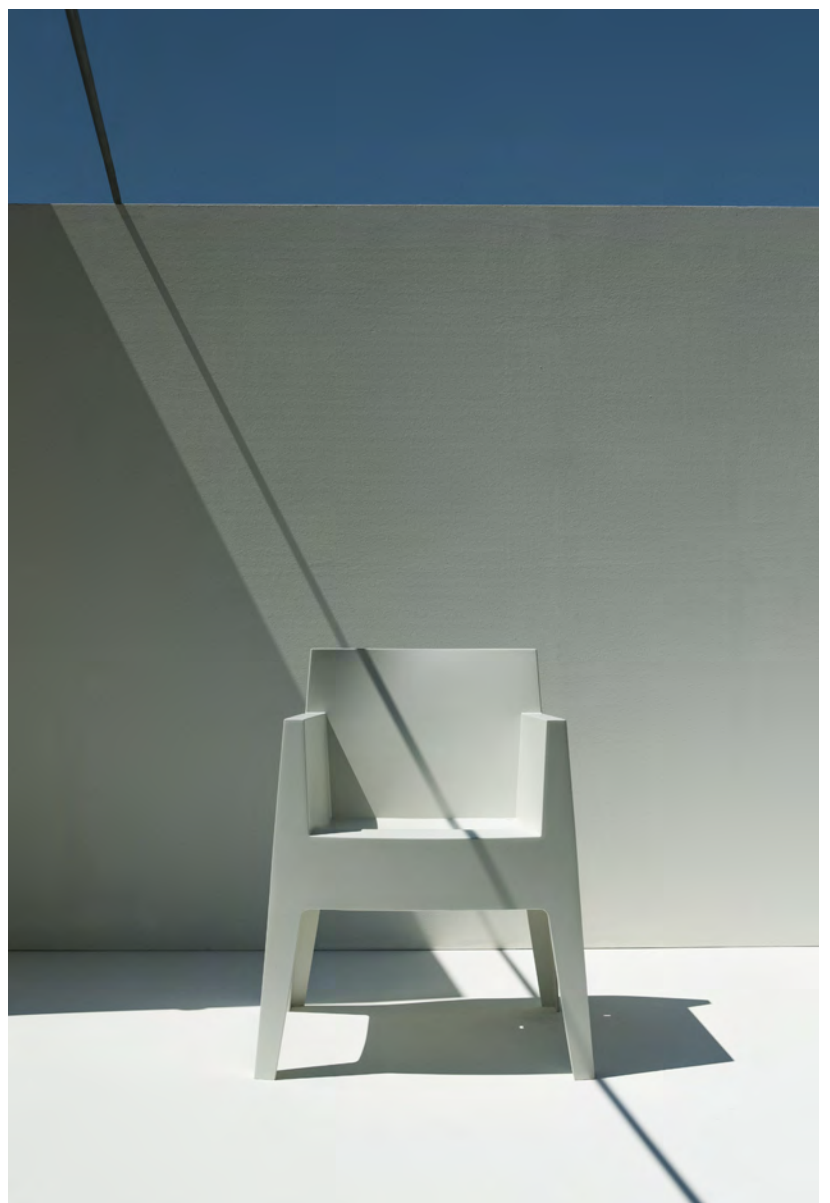



lord yo

DESIGN _ PHILIPPE STARCK



Inizialmente Lord Yo era semplicemente una poltroncina in polipropilene con struttura in alluminio, oggi è un'icona. Costruita con morbide curve e schienale rialzato; quasi un trono.

At its beginning, Lord Yo was simply a polypropylene easychair with an aluminum structure, now it's an icon. With soft curves and raised back; almost a throne.





bo

DESIGN _ PHILIPPE STARCK

Sedia dalla silhouette slanciata ed ergonomica, perfetta per l'outdoor così come per gli interni più contemporanei.

Bo chair is characterized by a soar and ergonomic silhouette. Perfect for outdoor or contemporary indoor.







clover

DESIGN _ RON ARAD

Le poltrone possono diventare fiori?
Fiori di una specie sconosciuta dotati di quattro petali carnosì e di forti radici.

Can armchairs become flowers? Flowers of an unknown species with four fleshy petals and strong roots.

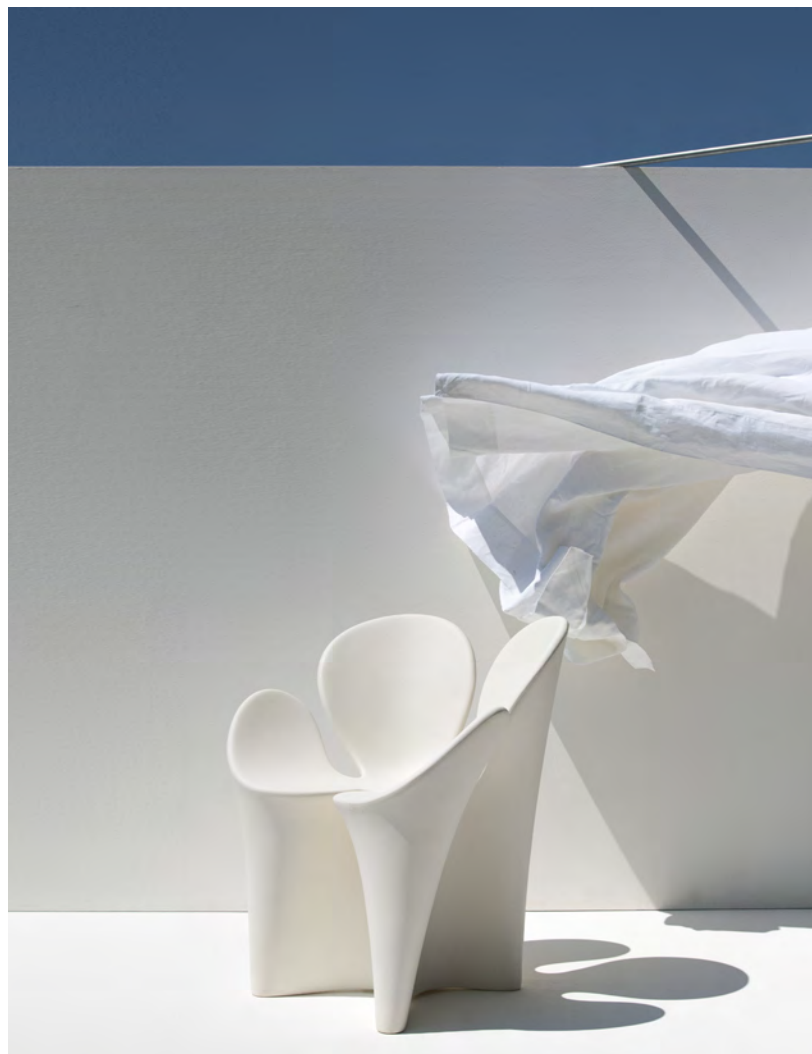



modesty veiled

DESIGN _ ITALO ROTA



La qualità di essere modesta: la libertà dalla vanità, riguardo per la decenza di comportamento, di linguaggio, d'abbigliamento, semplicità, moderazione, progettata per evitare l'esposizione accidentale di una parte del corpo, un lembo di pudore, di mansuetudine.

The quality of being modest: the freedom from vanity, the respect for discretion in the conduct, in the language, in the clothing, the simplicity, the moderation, designed to prevent the accidental exposure of a body part, a strip of modesty, of meekness.



kalimba

DESIGN _ DRIADE LAB

Kalimba, nome che trae ispirazione da un antichissimo strumento a percussione africano, è il nuovo tavolo outdoor disegnato da DriadeLab, il centro di ricerca e cuore creativo interno all'azienda. Innovativo tavolo in alluminio con piano a effetto doghe, eco-sostenibile e durevole, è l'elemento d'arredo perfetto per ogni situazione. Funzionale e minimale, dalle linee geometriche nette, pensato per adattarsi a qualsiasi spazio e ad ogni tipologia di giardino o terrazzo.

Kalimba, a name inspired by an ancient African percussion instrument, is the new outdoor table designed by DriadeLab, the company's research centre and creative heart. Aluminium table with a slatted effect top, eco-sustainable and durable, it is the perfect piece of furniture for any situation. Functional and minimalist, with clear geometric lines, designed to fit into any space and any type of garden or terrace.









app

DESIGN _ LUDOVICA + ROBERTO PALOMBA

Il tavolino App, pensato principalmente per l'outdoor, offre possibilità di utilizzo poliedriche e trasversali. Slanciato ed elegante, è caratterizzato da un piano quadrato e da quattro gambe che si raccordano nella parte alta della struttura offrendo al tavolo un'immagine di grande leggerezza. Realizzato in plastica rotazionale, è disponibile nelle varianti nero o bianco.

The small table App, mainly intended for outdoor use, is ideal for versatile wide functions. Slender and sophisticated, it has a square top and four legs that converge at the top of the frame, enhancing the table with extreme lightness. Produced in rotational plastic, it is available in the variants black, or white.











lord yi

DESIGN _ PHILIPPE STARCK

Il tavolino Lord Yi sorprende per la sua essenzialità e per la chiara composizione delle parti, volutamente segnalata nella sua tripartizione di base, fusto e piano.

Lord Yi table is surprising for its simplicity and the clear composition of the parties, deliberately signaled in his tripartite division of base, shaft and top.







kissi kissi

kissino

DESIGN _ MIKI ASTORI



Tavolino essenziale
caratterizzato
dalla plasticità
delle forme.

Essential table
characterized
by malleable
forms.

A close-up photograph of a black leather chair with white stitching. The chair is positioned diagonally, showing the seat and a portion of the backrest. The leather has a subtle texture, and the stitching is a contrasting light color. The background is a bright, out-of-focus white.

Index

sedie / chairs



11 **costes**
design Philippe Starck



15 **king costes**
design Philippe Starck



16 **pratfall**
design Philippe Starck



18 **la francesa**
design Lievore
Altherr Molina



23 **lou eat**
design Philippe Starck
with D. Sugawara



29 **miss lacy**
design Philippe Starck



30 **soirée**
design Oscar
e Gabriele Buratti



36 **mingx**
design Konstantin Grcic



41 **meridiana**
design Christophe Pillet



44 **lago'**
design Philippe Starck



48 **liba**
design Borek Sipek



51 **neoz**
design Philippe Starck



52 **sof sof**
design Enzo Mari



192 **tottori**
design Kateryna Sokolova



54 **millepiedi**
design Studio Catoir



58 **blocco**
design Nanda Vigo

tavoli e tavolini / tables and coffee tables



63 **sangaku**
design Elena Salmistraro



67 **tottori**
design Kateryna Sokolova



69 **frate**
design Enzo Mari



72 **fratello**
design Enzo Mari



77 **cugino**
design Enzo Mari



78 **cuginetto**
design Enzo Mari



81 **françois**
design Lievore Altherr



86 **fourdrops**
design Oscar e Gabriele Buratti



93 **easel**
design Ludovica + Roberto Palomba



97 **anapo**
design Gordon Guillaumier



102 **didymos**
design Antonia Astori



108 **mingx**
design Konstantin Grcic



110 **gazelle**
design Park Associati



113 **meridiana**
design Christophe Pillet



koishi
design Naoto Fukasawa



119 **sereno**
design Fredrikson Stallard



122 **carmina**
design Ludovica + Roberto Palomba



125 **basalt**
design Fredrikson Stallard



126 **zagazig**
design DriadeLab



129 **waterfall**
design Fredrikson Stallard



131 **portable atelier**
design Philippe Nigro



132 **ping I, II**
design Giuseppe Chigiotti



133 **picapica**
design Kazuyo Sejima

contenitori e librerie / cabinets and bookcases



137 **love**
design Fabio Novembre



140 **hidalgo**
design DriadeLab



144 **ziquurat**
design DriadeLab



153 **ercole e afrodite**
design DriadeLab



160 **venus**
design Fabio Novembre



163 **zigzag**
design Konstantin Grcic



167 **virgo**
design Xavier Lust

complementi d'arredo / furnishing accessories



170 **nemo miniatura flocked**
design Fabio Novembre



172 **nemo miniatura**
design Fabio Novembre



175 **hanahana**
design Kazuyo Sejima



176 **acate**
design Borek Sipek

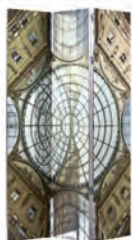

179 **miro**
design Francesco Bolis



180 **archipelago**
design Fredrikson Stallard

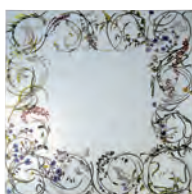

182 **egeso**
design Bertocco & Locatelli



183 **taylor and snijder bird**
design Ed Annink



184 **osmond**
design Pietro Derossi



187 **erbale**
design Becchelli, Bortolani, Maffei

poltrone e divani / armchairs and sofas



192 **tottori**
design Kateryna Sokolova



197 **wireflow**
design Michel Rojkind



200 **italic**
design Fabio Novembre



203 **lou read**
design Philippe Starck
with Eugeni Quitllet



207 **lou speak**
design Philippe Starck



211 **moon**
design Ludovica + Roberto Palomba



214 **cinemascope**
design Philippe Starck



219 **viglius**
design Matteo Thun & Antonio Rodriguez



220 **ten**
design Naoto Fukasawa



223 **lisa**
design Laudani & Romanelli



225 **s.marco**
design Matteo Thun
& Antonio Rodriguez



226 **s.marco lounge**
design Matteo Thun
& Antonio Rodriguez



231 **pavo, pavo real**
design Patricia Urquiola



232 **suki**
design Toyo Ito



237 **wow, wow low back**
design Philippe Starck



243 **fenix**
design Ludovica + Roberto Palomba



246 **lirico**
design Ludovica + Roberto Palomba



251 **lirica**
design Ludovica + Roberto Palomba



253 **hall**
design Rodolfo Dordoni



256 **neil**
design Ludovica + Roberto Palomba



263 **33 cuscini**
design Paolo Rizzatto



267 **leon soft**
design Ludovica + Roberto Palomba



271 **rever**
design Ludovica + Roberto Palomba



275 **verlaine**
design Lievore Altherr Molina



276 **elisa**
design Enzo Mari



280 **mod**
design Ludovica + Roberto Palomba



283 **mody**
design Ludovica + Roberto Palomba

outdoor



287 **nemo**
design Fabio Novembre



292 **roly poly** series
design Faye Toogood



297 **tokyo-pop** series
design Tokujin Yoshioka



299 **pliè**
design Ludovica + Roberto Palomba



299 **gran pliè**
design Ludovica + Roberto Palomba



299 **piaffè**
design Ludovica + Roberto Palomba



306 **mt 1, mt 2, mt 3** series
design Ron Arad



310 **mingx** series
design Konstantin Grcic



313 **elisa** series
design Enzo Mari



315 **sissi**
design Ludovica + Roberto Palomba



319 **pip-e**
design Philippe Starck
with Eugeni Quitllet



323 **toy**
design Philippe Starck



325 **lord yo**
design Philippe Starck



326 **bo**
design Philippe Starck



329 **clover**
design Ron Arad



331 **modesty veiled**
design Italo Rota



333 **kalimba**
design DriadeLab



337 **app**
design Ludovica + Roberto Palomba



342 **lord yi**
design Philippe Starck



345 **kissi kissi, kissino**
design Miki Astori

MASTHEAD

Art Direction

DriadeLab

Photo

Iacopo Barattieri

Max Zambelli

Francesco Bolis

Claudio Tajoli

Saverio Lombardi

Tom Vack

Lorenzo Cicconi Massi

Andrea Garuti

Thanks to

Altai

Bisazza Spa

CC-Tapis Mazalli Srl

FontanaArte Spa

Gigacer Spa

Margaritelli Spa

Misha Wallpaper Srl

Par-Ky Italia Srl

Texidores SCCI

Print

Faenza Group Spa

June 2022

driade

Alzaia Trieste, 49

20094 Corsico (MI), Italy

driade.com

@driade_it

